

Texart

XT-640 **USER'S MANUAL**

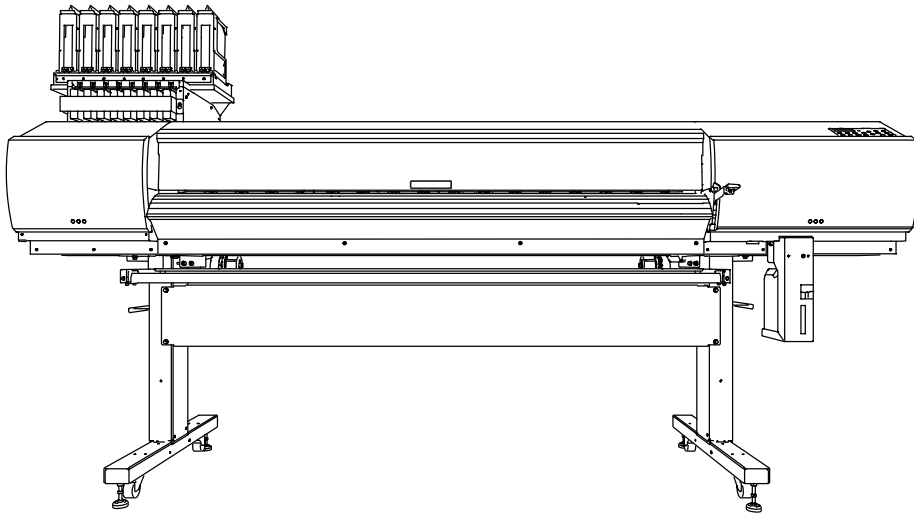

Thank you very much for purchasing this product.

- To ensure correct and safe usage with a full understanding of this product's performance, please be sure to read through this manual completely and store it in a safe location.
 - Unauthorized copying or transferral, in whole or in part, of this manual is prohibited.
 - The specifications of this product and the contents of this manual are subject to change without notice.
 - This manual and the product have been prepared and tested as much as possible. If you find any misprints or errors, please inform Roland DG Corp.
 - Roland DG Corp. assumes no responsibility for any direct or indirect loss or damage that may occur through use of this product, regardless of any failure to perform on the part of this product.
 - Roland DG Corp. assumes no responsibility for any direct or indirect loss or damage that may occur with respect to any article made using this product.
-

Roland DG Corporation

This product is equipped with an "eT-Kernel Multi-Core Edition" eT-Kernel and a "PrConnect(R)/Pro" TCP/IP protocol stack, both made by eSOL Co., Ltd. eT-kernel and PrConnect are registered trademarks of eSOL Co., Ltd.

Roland DG Corp. has licensed the MMP technology from the TPL Group.

Contents

Contents	1
Chapter 1 Machine Highlights	5
Part Names and Functions	6
Printer Unit.....	6
Operation Panel	8
⚠Warning Labels.....	9
⚠Vignettes d'avertissement	10
Menu List.....	11
Main Menu.....	11
Language and Unit Menu.....	14
Cleaning Menu	14
Dryer Settings Menu	15
Important Notes on Handling and Use	16
Chapter 2 Basic Operation.....	17
Preparing Media	18
Types of Media	18
Conditions for Usable Media.....	18
Media Storage Environment	19
Switch On!.....	20
Switch On!.....	20
Sleep Mode (Power-saving Feature)	20
Loading Media	21
Loading Roll Media	21
Loading Sheet Media	37
Performing the Initial Adjustment (Correcting for Misalignment in Bidirectional Printing More Precisely).....	40
Setup of Media	42
About "MEDIA SETTING" menu	42
Setup of Media ("MEDIA SETTING" menu).....	42
Print.....	48
Setting the Printing-start Location	48
Printing Tests and Normal Cleaning	49
Getting Ready to Receive Data from a Computer	52
Starting Printing.....	53
Remaining Ink during Printing	53
If a Cover Opens during Operation	54
Pausing or Canceling Printing.....	54
Cutting Off the Media.....	55
Transfer conditions	56
Switch Off.....	57
Switch Off.....	57
Chapter 3 Maintenance: Keeping the Machine in Good Working Order.....	59
Ink Pouch Replacement	60
Out-of-ink Warnings.....	60
Ink Pouch Replacement	61

Maintenance That Should Be Performed Daily	63
Disposing of Discharged Fluid.....	63
Cleaning.....	65
Care and Maintenance of the Print Heads.....	66
When Normal Cleaning Is Not Effective	67
Medium Cleaning.....	67
Powerful Cleaning.....	68
If Colors Are Uneven	69
Mixing the Ink by Shaking the Ink Pouch	69
Light Choke Cleaning.....	69
Maintenance That Should Be Performed More than Once a Month	71
When Manual Cleaning Becomes Necessary	71
Manual Cleaning.....	72
Maintenance That Should Be Performed Every Six Months	78
Refreshing Subtanks (REFRESH SUBTANKS).....	78
When Problems Such as Dot Drop-Out Are Not Fixed	81
When Problems Such as Dot Drop-Out Are Not Fixed.....	81
Replacing Consumable Parts.....	83
Replacing the Wiper	83
Replacing the Felt Wiper.....	86
Replacing the Separating Knife.....	89
When Not in Use for a Prolonged Period	91
Keep Performing Maintenance	91
Alarm Feature	91
If the Machine has not been Used for Over One Month	91
Chapter 4 Advanced Functions	93
Fully Utilizing the Preset Function	94
Saving Various Settings as a Name Assigned Preset.....	94
Loading a Saved Preset	95
Automatic Loading of a Saved Preset When Media Is Loaded	96
Using the Dryer	97
What is the Dryer?	97
Setting the Temperature of the Dryer.....	98
Dryer Control While Idling.....	99
Drying the Trailing Edge of the Printing Area on the Dryer.....	100
Setting the Drying Time after Printing.....	101
Fully Utilizing the Correction Function.....	102
Correcting for Misalignment in Bidirectional Printing.....	102
Correcting for Misalignment in Bidirectional Printing More Precisely.....	102
Reducing Horizontal Bands (Feed Correction Function).....	103
Correcting Media Skew	104
Accommodating Different Media Types and Conditions.....	106
Adjusting Print Head Height to Match Media Thickness	106
Using Transparent Media.....	107
Using Hard-to-Dry Media	109
Using Media That Does Not Move Smoothly	109
Changing the Range of Print-head Carriage Movement	110
Expanding the Printing Area by Reducing the Margins.....	111

Preventing Soiling of the Media and Dot Drop-Out.....	112
Using Sticky Media.....	113
Printing with Crop Marks	114
Printing with Crop Marks.....	114
Using the Media Take-Up System	115
Using the Media Take-up System	115
Important Notice When Using the TUC-3	115
Chapter 5 To Administrators	117
Output Operation Management.....	118
Printing a System Report	118
Determining What Happens When Ink Runs Out	118
Displaying the Amount of Media Remaining.....	119
Making Sure to Verify the Setting for the Amount Remaining Every Time the Media Is Changed	120
Printing the Amount of Remaining Media.....	121
System Management of Printer.....	122
Setting Menu Language and Units of Measurement	122
Setting Activation Interval for Sleep Mode (Power-Saving Feature)	122
Viewing System Information.....	123
Returning All Settings to Their Factory Default Values.....	124
Changing Installation Location	125
Chapter 6 Read This Chapter Whenever You Face a Problem (FAQ)	127
Attractive Printing is Impossible	128
Printed Results Are Coarse or Contain Horizontal Stripes	128
Colors Are Unstable or Uneven	129
The Media Becomes Soiled When Printed.....	130
Color Mixing Occurs	131
A Media Jam Occurs!	132
The Media Has Jammed.....	132
Media Feed Is Not Smooth	133
Media Wrinkles or Shrinks	133
Media Feeding Is Not Straight	134
Media Feeding Is Not Smooth	134
Why Has the Print-Head Carriage Stopped Moving?	135
What to Do First	135
If the Print-Head Carriage Still Do Not Move.....	135
Other Problems	137
The Machine Does Not Move.....	137
Cannot Cut Off the Media	139
Dryer Does Not Become Hot.....	139
It Is Not Possible to Check the Amount of Discharged Fluid in the Drain Bottle.....	139
A Message Appears	140
An Error Message Appears	142
Chapter 7 Main Specifications.....	147
Printing Area.....	148
Maximum Printing Area and Margins	148
Maximum Printing Area When Using Crop Marks	149

Media-Cutoff Location during Continuous Printing.....	149
Locations of Power Rating and Serial Number Labels.....	150
Specifications	151

Chapter 1

Machine Highlights

Part Names and Functions	6
Printer Unit	6
Operation Panel	8
⚠ Warning Labels	9
⚠ Vignettes d'avertissement	10
Menu List	11
Main Menu	11
Language and Unit Menu	14
Cleaning Menu	14
Dryer Settings Menu	15
Important Notes on Handling and Use	16
Printer Unit	16
Ink Pouches	16

Part Names and Functions

Printer Unit

Front

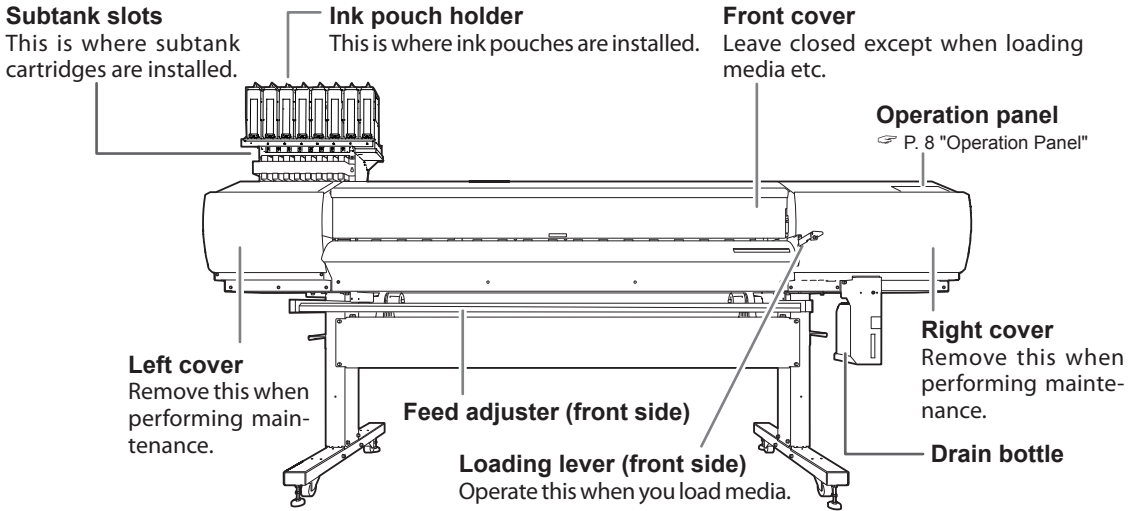

Back

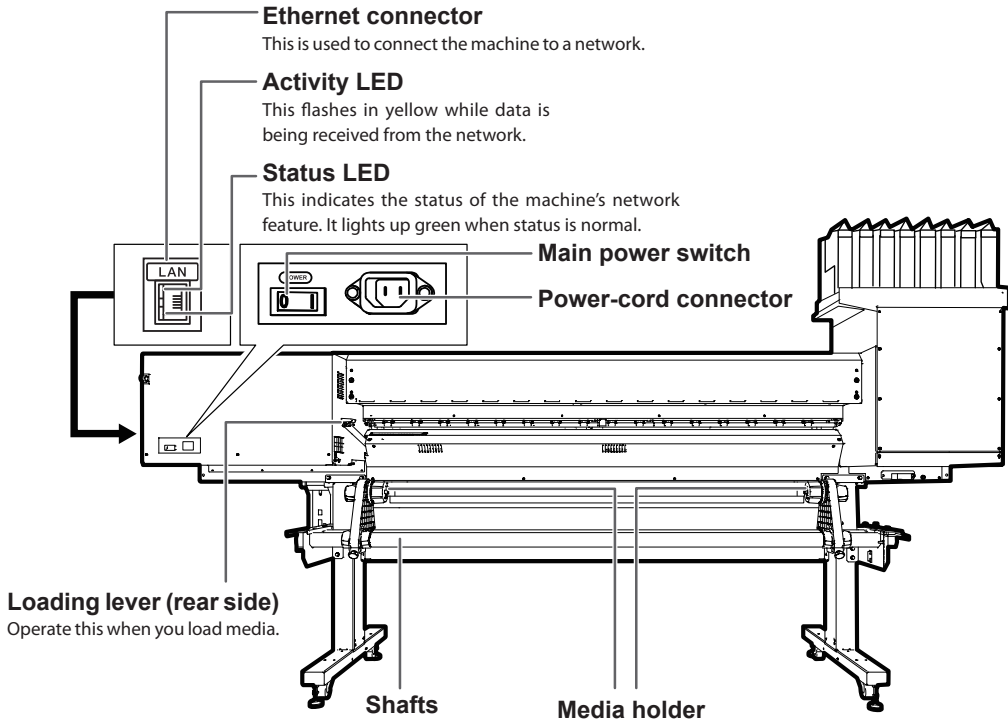

Front Cover Interior/Print Head Area

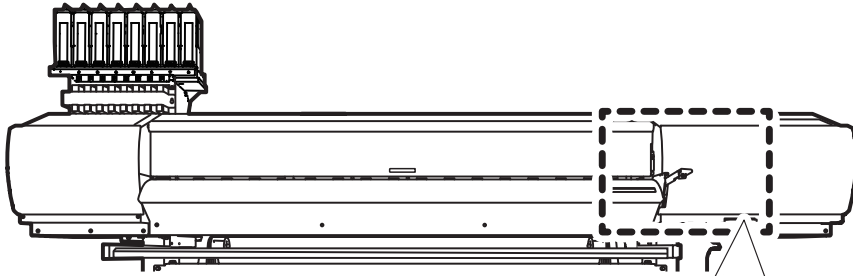

Print-head carriage

The print heads are equipped inside this.

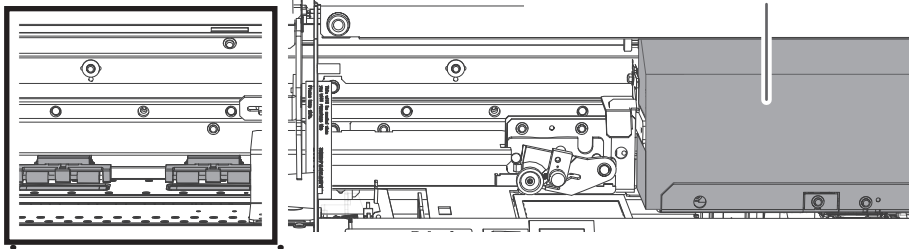

Pinch rollers

These clamp the media when the loading lever is lowered.

Grit rollers

These rollers feed out media toward the front of the machine.

Knife guide

The separating knife travels along this guide when separating the media.

Platen

This is the path over which the media passes. A suction fan that keeps the media from coming loose is built in.

Apron



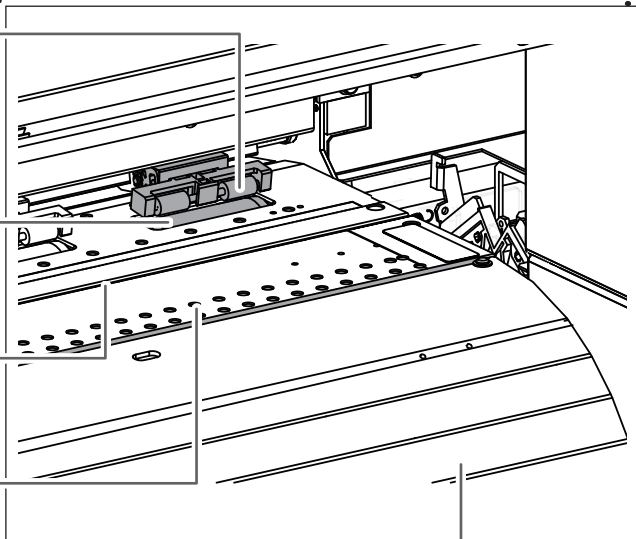





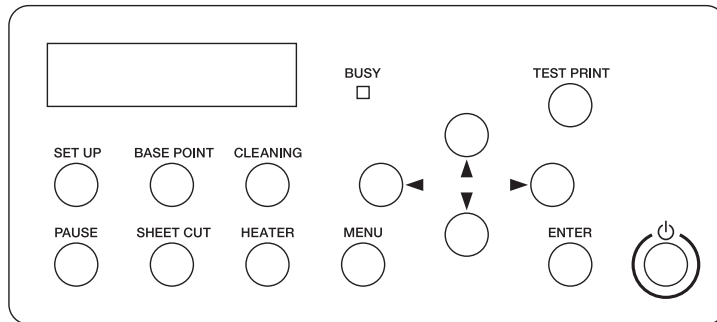













This has a built-in dryer to speed up drying of the ink.



Operation Panel

1 Machine Highlights



Part	Name	Description	Illustration in this manual
	Display screen	This displays various setting menus and other information.	
	Sub power switch	This switches the printer on and off. (To switch the printer off, hold down the switch for one second or longer). The light flashes slowly when the machine is in sleep mode.	
	ENTER key	Use this for such tasks as enabling setting values.	
	MENU key	Press this to enter the menus for various settings.	
	HEATER key	Press this to set the temperature for the dryer. This flashes while the media heating system is warming up and remains lit once the preset temperature is reached.	
	SHEET CUT key	Hold down this key for one second or longer to cut off the media.	
	PAUSE key	This pauses the printing operation. It lights when operation is paused.	
	SETUP key	Press this when you load media. It lights when media is loaded and the machine is ready to perform output.	
	BASE POINT key	Use this when you want to set the output-start location. It lights when the setting has been made.	
	CLEANING key	Use this to clean the print heads.	
	Cursor keys	Use these to select settings for menu items, to move the media, and for other such operations.	
	TEST PRINT key	Hold this down for one second or longer to perform a printing test.	
	BUSY light	This lights during printing and other such operations.	

! Warning Labels

Warning labels are affixed to the machine to make areas of danger immediately clear. The meanings of these labels are as follows. Be sure to heed their warnings. Also, never remove the labels or allow them to become obscured.

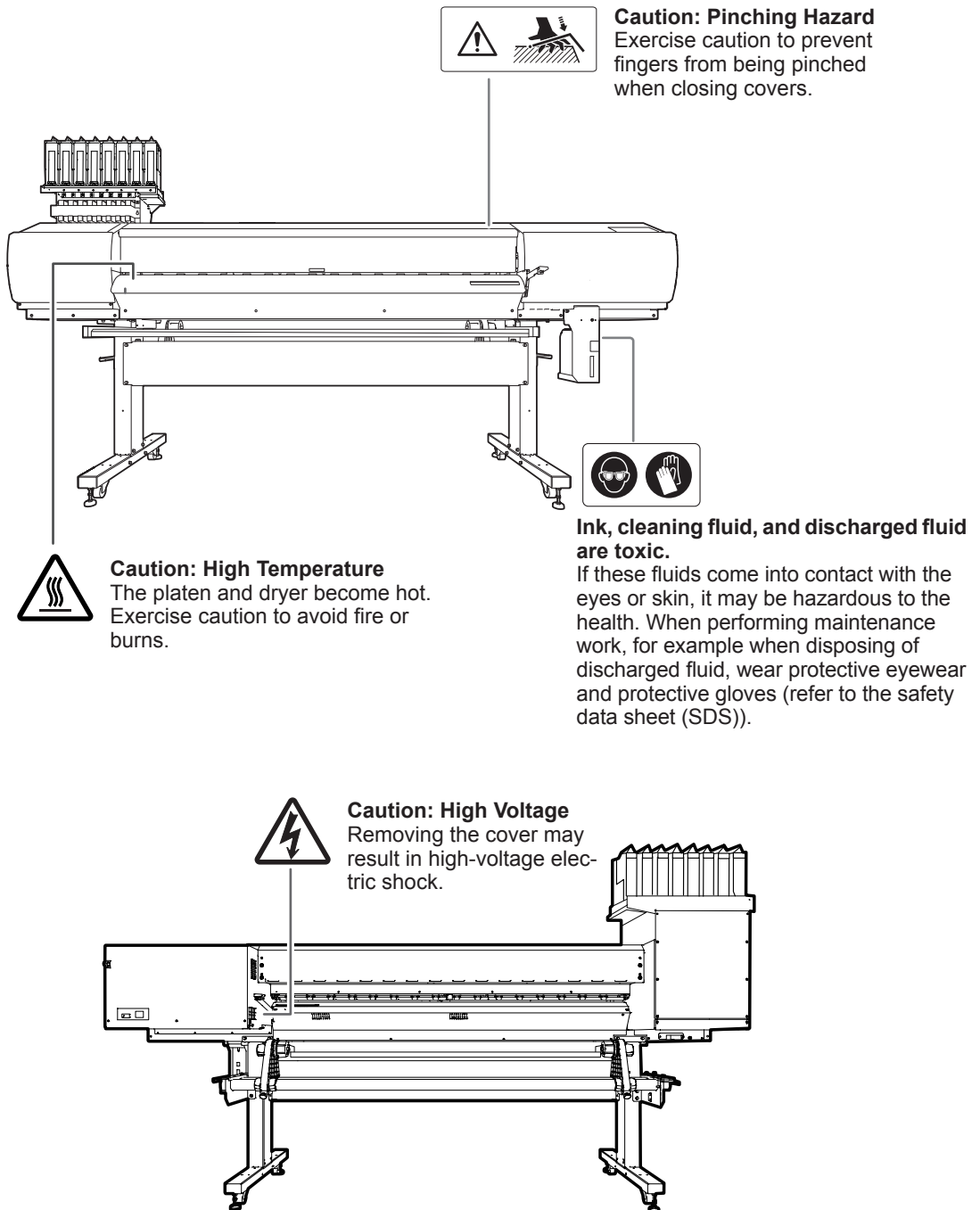

⚠ Vignettes d'avertissement

Des vignettes d'avertissement sont apposées pour qu'il soit facile de repérer les zones dangereuses. La signification des vignettes est donnée ci-dessous. Respecter les avertissements. Ne jamais retirer les vignettes et ne pas les laisser s'encrasser.

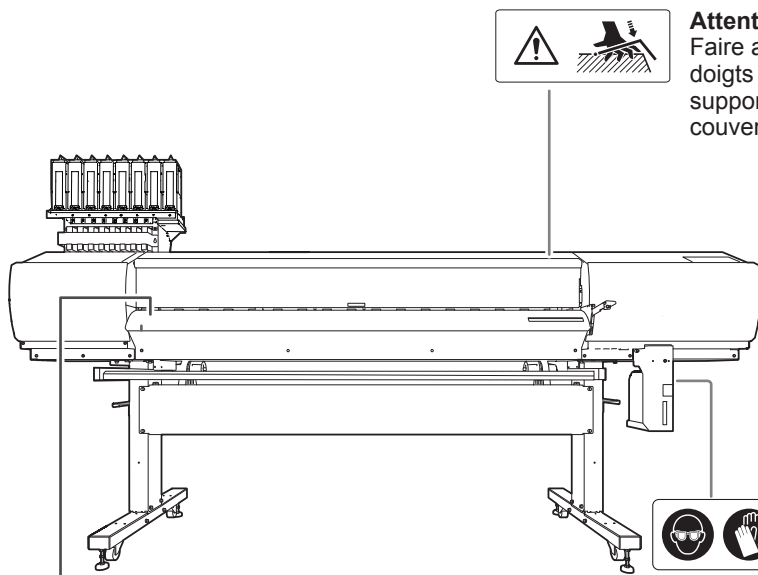

Attention : Risque de pincement
Faire attention de ne pas coincer les doigts pendant le chargement du support ou lors de la fermeture du couvercle.



Attention : Température élevée
La platine et la surface de séchage chauffent. Être prudent pour éviter un incendie ou des brûlures.



L'encre, le liquide de nettoyage et le rejet liquide sont toxiques
Il peut s'avérer dangereux pour la santé si ces liquides viennent en contact avec les yeux ou la peau. Lors de travaux d'entretien, à l'élimination de rejets liquides par exemple, utilisez une protection oculaire et des gants protecteurs (se reporter à la fiche signalétique [FS]).



Attention : voltage élevé
Il peut être dangereux de retirer le couvercle puisqu'il y aurait des risques de chocs électriques ou d'électrocution à cause du voltage élevé.

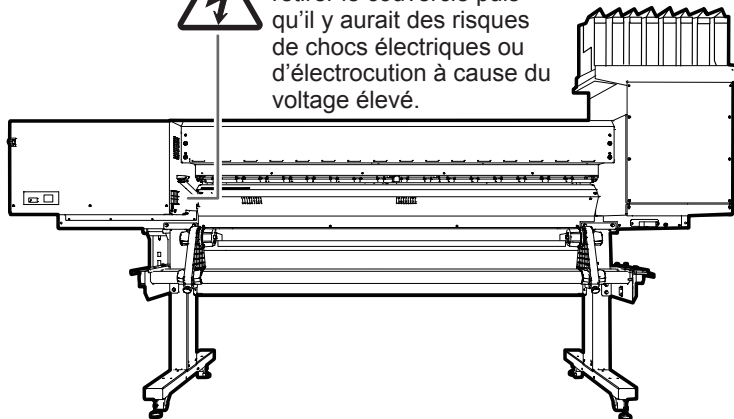

Menu List

Main Menu

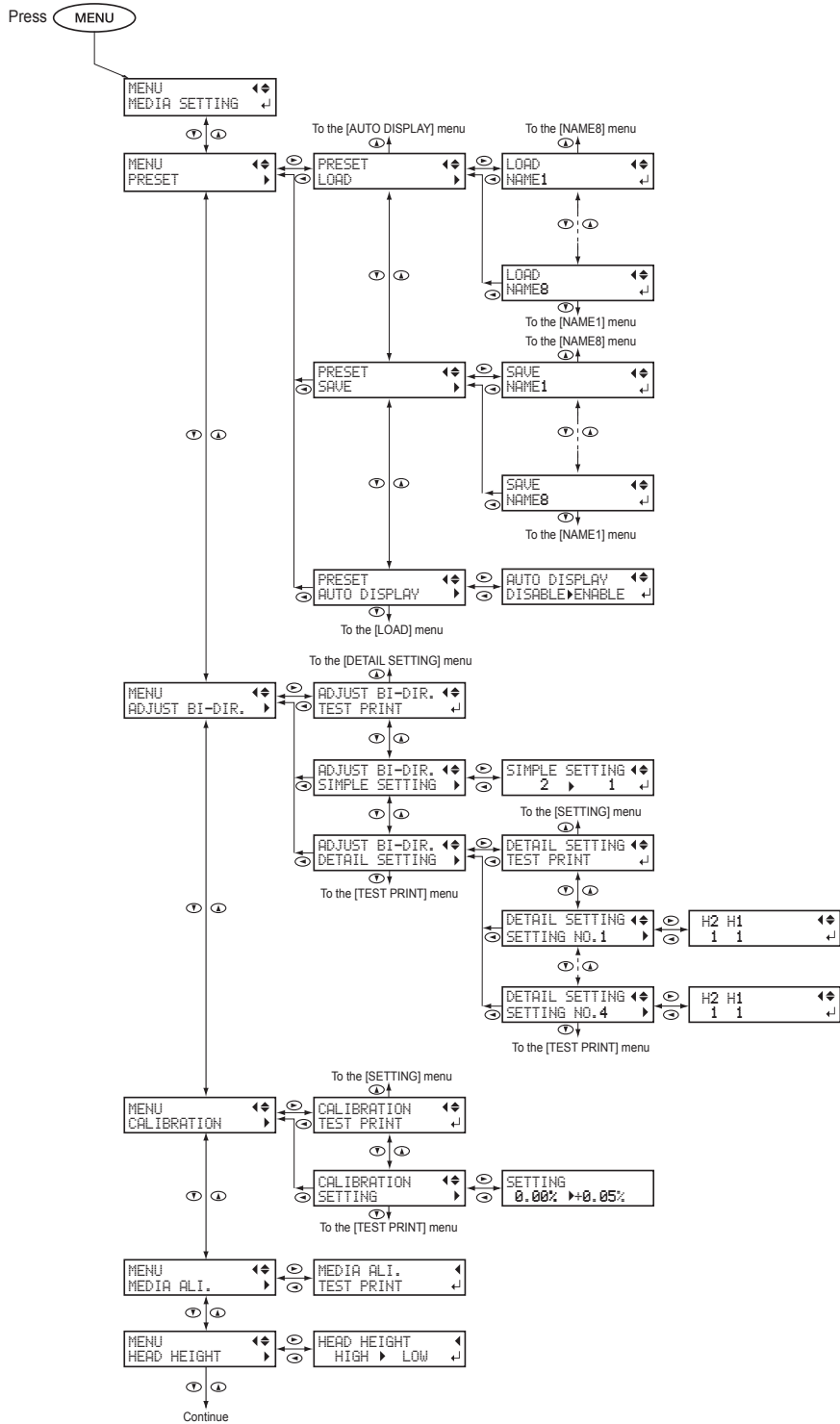

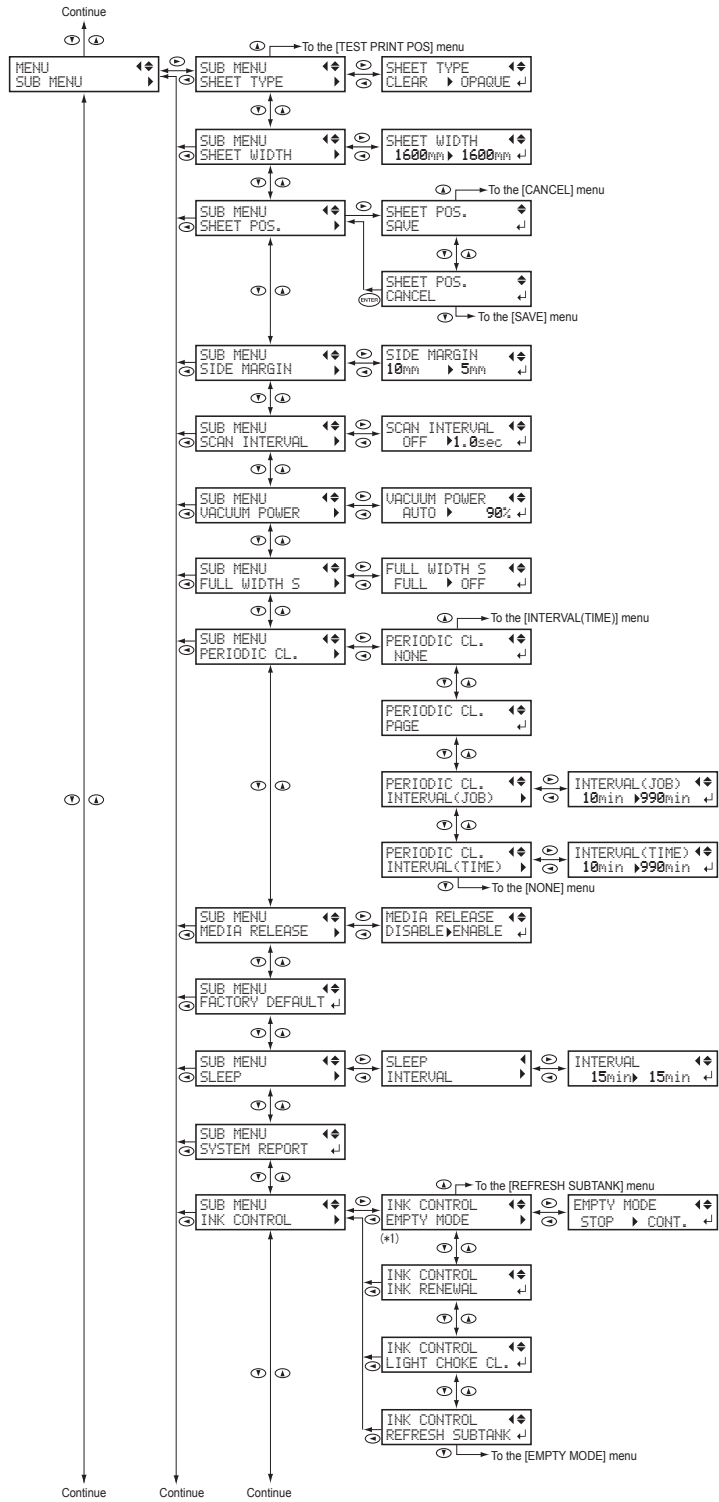

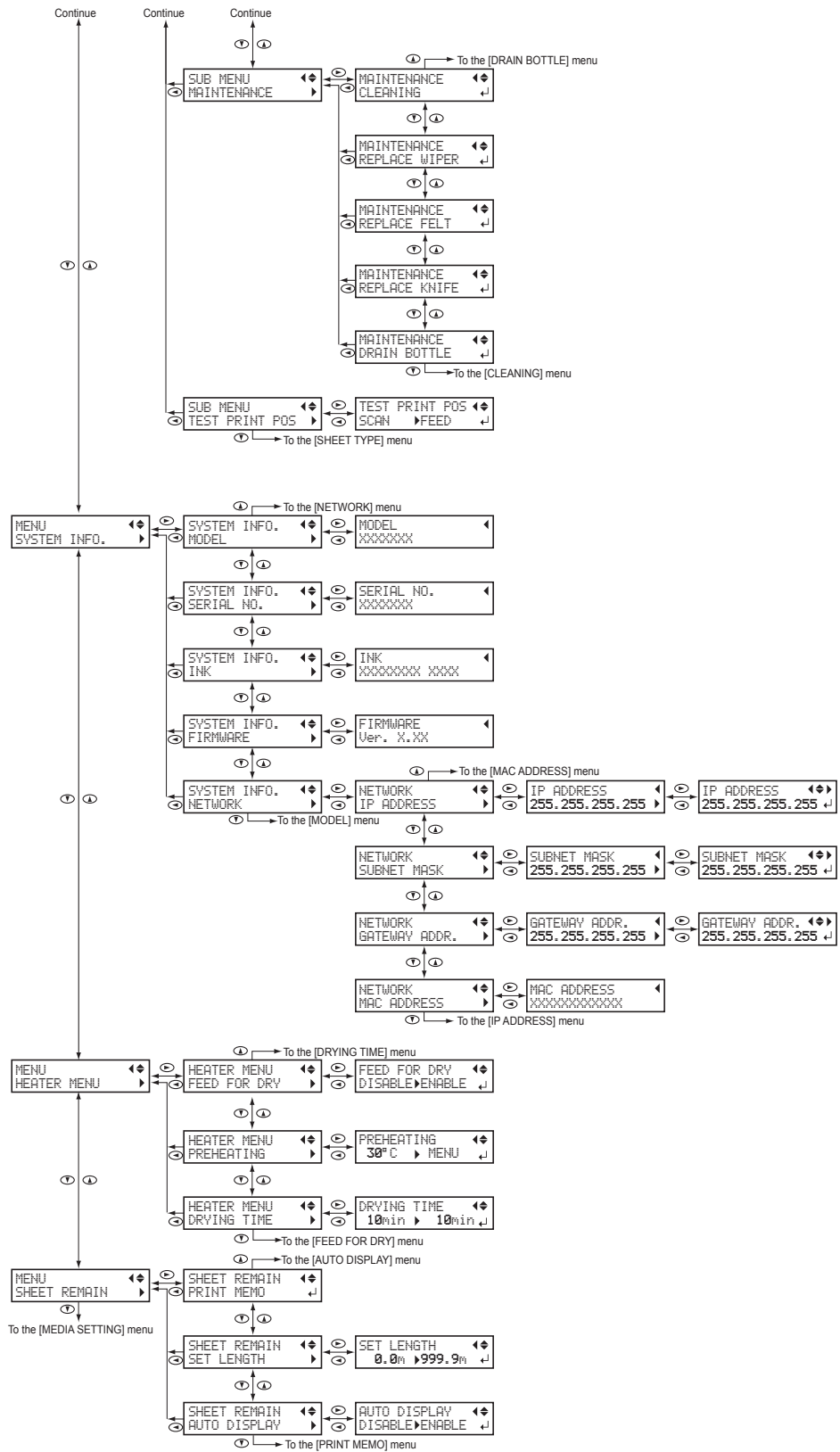

Language and Unit Menu

While holding down **MENU**, switch on the sub power.

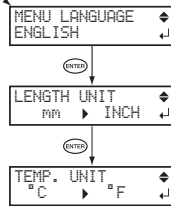

Cleaning Menu

Press **CLEANING**

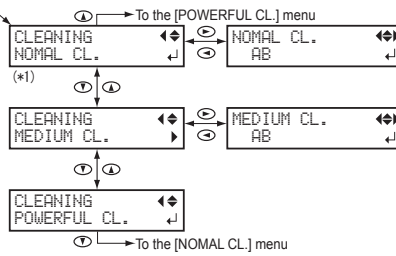

Hold down **CLEANING** for one second or longer.

Normal cleaning of all groups

Dryer Settings Menu

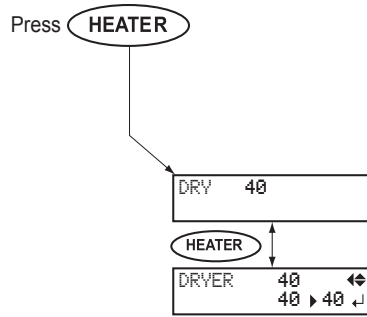

Important Notes on Handling and Use

This machine is a precision device. To ensure the full performance of this machine, be sure to observe the following important points. Failure to observe them may not only result in loss of performance but may also cause malfunction or breakdown.

Printer Unit

This machine is a precision device.

- Never subject the machine to impacts or excessive force.
- Never needlessly put your hand or fingers inside the cover, the ink-pouch ports, or other internal areas of the machine.

Install the machine in a suitable location.

- Install the machine in a location having the specified temperature and relative humidity.
- Install the machine in a quiet, stable location offering good operating conditions.

The print heads are delicate.

- Never needlessly touch or allow media to scrape them.
- The print heads may be damaged if allowed to dry out. The machine prevents desiccation automatically, but improper operation may render this feature inoperative. Operate the machine properly, as specified in this manual.
- Never leave the machine with an ink pouch removed. The remaining ink in the printer may harden and clog the print heads.
- The print heads are components that wear out. Periodic replacement is required, with the frequency of replacement depending on use.

This machine becomes hot.

- Never cover the ventilation holes with cloth, tape, or anything else.

Ink Pouches

Ink pouches come in various types.

- Use a type that is compatible with the printer.

Never subject the machine to impacts or attempt to disassemble it.

- Never drop the machine or shake it forcefully. The impact may rupture the internal pouch and cause the ink to leak.
- Never attempt to disassemble the machine.
- Never attempt to refill the ink.
- If ink gets on your hands or clothing, wash it off as soon as possible. Removal may become difficult if you leave such adhered ink untreated.

Storage

- Store unopened in a well-ventilated location at a temperature of 5 to 30°C (-4 to 86°F).

Chapter 2

Basic Operation

Preparing Media.....	18
Types of Media.....	18
Conditions for Usable Media.....	18
Media Storage Environment.....	19
Switch On!.....	20
Switch On!.....	20
Sleep Mode (Power-saving Feature)	20
Loading Media	21
Loading Roll Media	21
Loading Sheet Media	37
Performing the Initial Adjustment (Correcting for Misalignment in Bidirectional Printing More Precisely)	40
Setup of Media.....	42
About "MEDIA SETTING" menu	42
Setup of Media ("MEDIA SETTING" menu)	42
Print.....	48
Setting the Printing-start Location	48
Printing Tests and Normal Cleaning.....	49
Getting Ready to Receive Data from a Computer.....	52
Starting Printing.....	53
Remaining Ink during Printing.....	53
If a Cover Opens during Operation	54
Pausing or Canceling Printing.....	54
Cutting Off the Media	55
Transfer conditions.....	56
Switch Off.....	57
Switch Off.....	57

Preparing Media

Types of Media

In this manual, the paper used for printing is called "media." There are the following main two media types used in this machine.

- **Roll media: Media wound onto a paper tube**
- **Sheet media: Media not wound onto a paper tube such as standard-size media**

Various paper qualities of roll media and sheet media are selectable according to the purpose. For detailed information about each media, contact your media supplier.

Conditions for Usable Media

This machine cannot print on every kind of media. When selecting media, be sure to carry out testing in advance to make sure that satisfactory printing results are obtained.

Size

Width (*a)	259 to 1,625 mm (10.2 to 64 in.)
Maximum media thickness (*a)	1.0 mm (39 mil)
Roll outer diameter	210 mm (39 mil)
Paper tube (core) inner diameter	76.2 mm (3 in.) or 50.8 mm (2 in.) (*b)

*a Applies to both roll and sheet media.

*b To use 2-inch media, the optional media flanges are required. For information about optional items, contact your authorized Roland DG Corp. dealer.

Maximum Roll Weight

40 kg (88 lb.)

Note: If using the take-up system, this specification depends on the conditions of media that can be used with the take-up system.

Other Conditions

Media such as the following cannot be used.

- Media whose end is attached to the paper tube (core)
- Media that is severely warped or that has a strong tendency to reroll
- Media whose paper tube (core) is bent or crushed
- Media that bends under its own weight when loaded
- Media on a sagging roll
- Media that is rolled unevenly

Media Storage Environment

Depending on the type of transfer paper, if it is stored in a humid environment for a long time, the coating of the paper may degrade and affect print quality. (In most cases, once the coating degrades, it will not return to its original condition.) Avoid storing transfer paper in humid environments.

Read the precautions regarding your media carefully, and store it in an appropriate environment. For details, contact your media supplier.

Switch On!

Switch On!

⚠️ WARNING

When output is not being performed, remove any loaded media or switch off the sub power.

The continued application of heat at a single location may cause the release of toxic gases from the media or pose a fire hazard.

Procedure

1

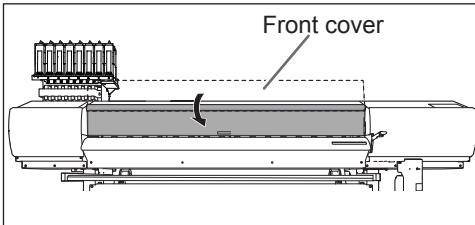

Close the front cover.

2

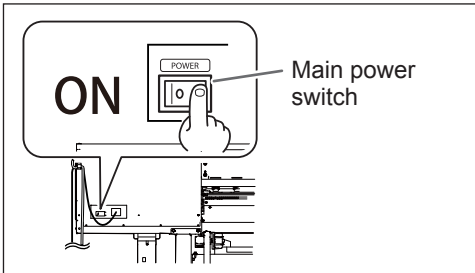

Switch on the main power.

3

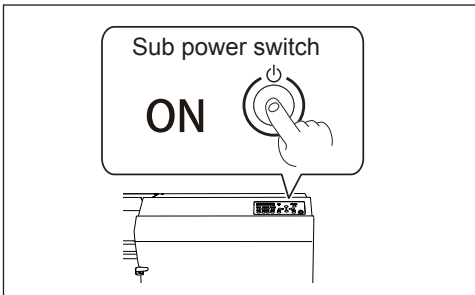

Switch on the sub power.

Sleep Mode (Power-saving Feature)

This machine is provided with a power-saving feature that switches to a low-power "sleep mode" when a fixed interval passes with no operation. The factory default for the time after which the machine switches to the sleep mode is 30 minutes. When the machine is in the sleep mode, the sub power switch flashes slowly. Using the operation panel or sending printing data from the computer restores the machine to its normal mode. This sleep mode setting can be changed. However, we recommend setting the activation time for the sleep mode to 30 minutes or less to reduce power consumption and prevent problems such as overheating.

☞ P. 122 "Setting Activation Interval for Sleep Mode (Power-Saving Feature)"

Loading Media

Loading Roll Media



Load roll media correctly.
Otherwise, the media may fall and cause injury.



Roll media weighs about 40 kg (88 lb.). To avoid injury, handle the roll media with care.



Do not load roll media that weighs more than 40 kg (88 lb.).
The machine may tip over because it is incapable of withstanding the weight.
Alternatively, the media may fall out of the machine.

1. Install the media on the media holders.

Note: The media holders of this machine are designed to be used exclusively with media that has a paper tube (core) with an inner diameter of 3 inches. To use 2-inch media, the optional media flanges are required. For information about optional items, contact your authorized Roland DG Corp. dealer.

1

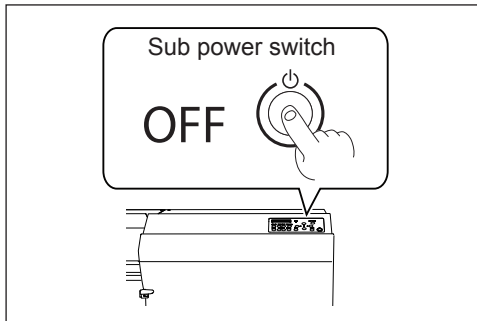

Switch off the sub power.

2

- 1 Loosen the securing screws of media holders.
- 2 Draw the media holders to both left and right ends respectively.

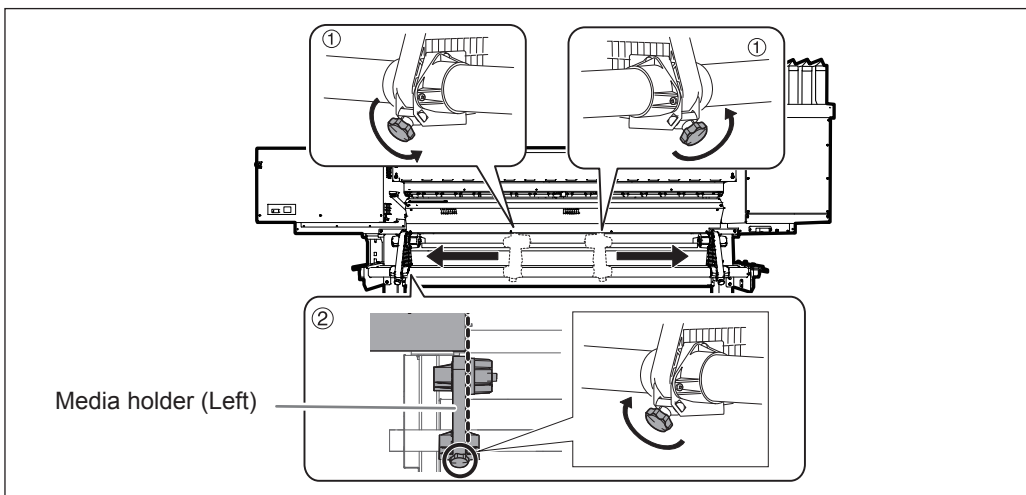

2

Basic
Operation

- 3 ① Fit the paper tube (core) of the media onto the end cap of the media holder (Left).
Do not secure the media holder now.
- ② Move the media holder (Right) and fit the end cap onto the paper tube (core) of the media.
Fit it securely to prevent the media from moving easily.

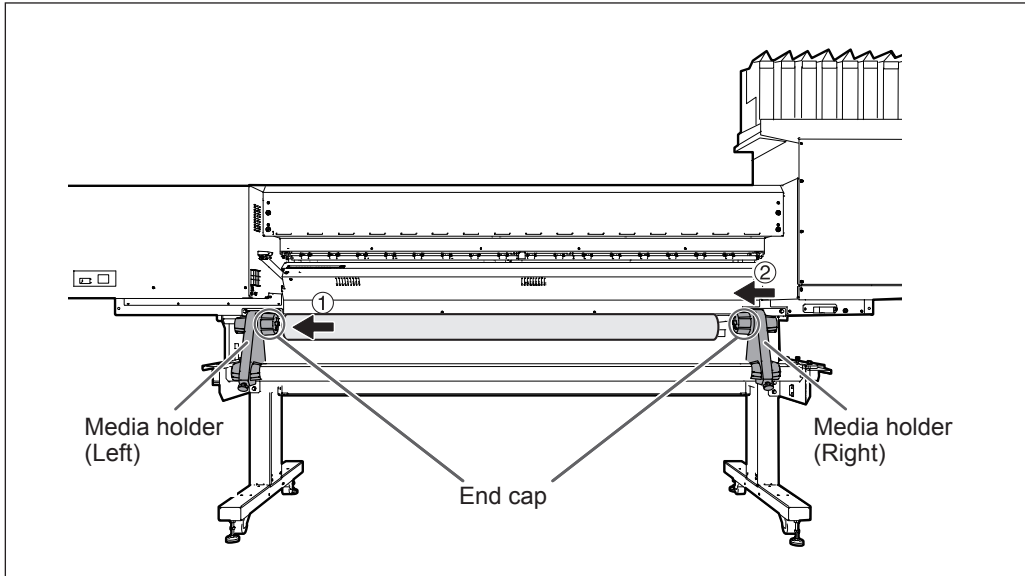

IMPORTANT! Install conforming to the procedures.

When loading the media make sure that the media holder (Left) is drawn to the left edge. Do not secure the media holder before loading the media. If these procedures are not followed, printing results will be affected because the media will not be fed correctly.

How to use media flanges for paper tubes (cores) with an internal diameter of 2 inches

Note: Media flanges for paper tubes (cores) with an internal diameter of 2 inches are optional items.

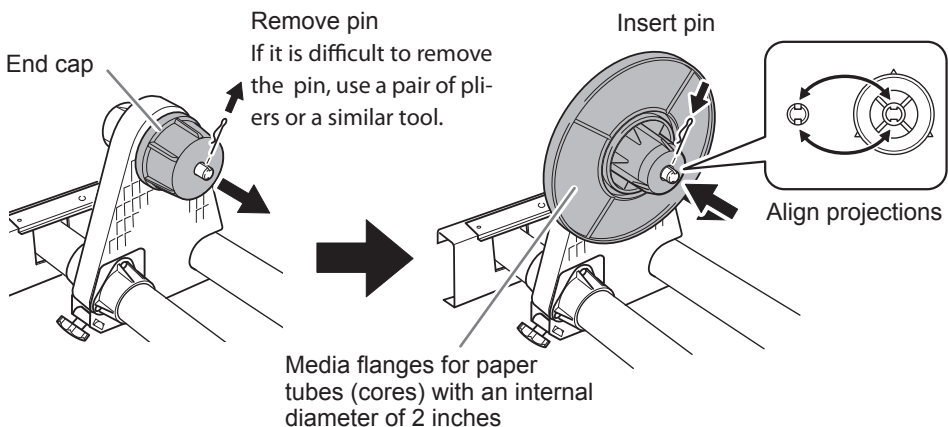

- 4 Hold the outer side of the media holder (Left) and position the left edge of the media to align with the marks.

When deciding the position, hold the both sides of media holders from the outer sides and move it. Do not hold the media directly to move.

CAUTION Do not hold places other than those instructed. Otherwise the media may fall off the media holder and cause injury.

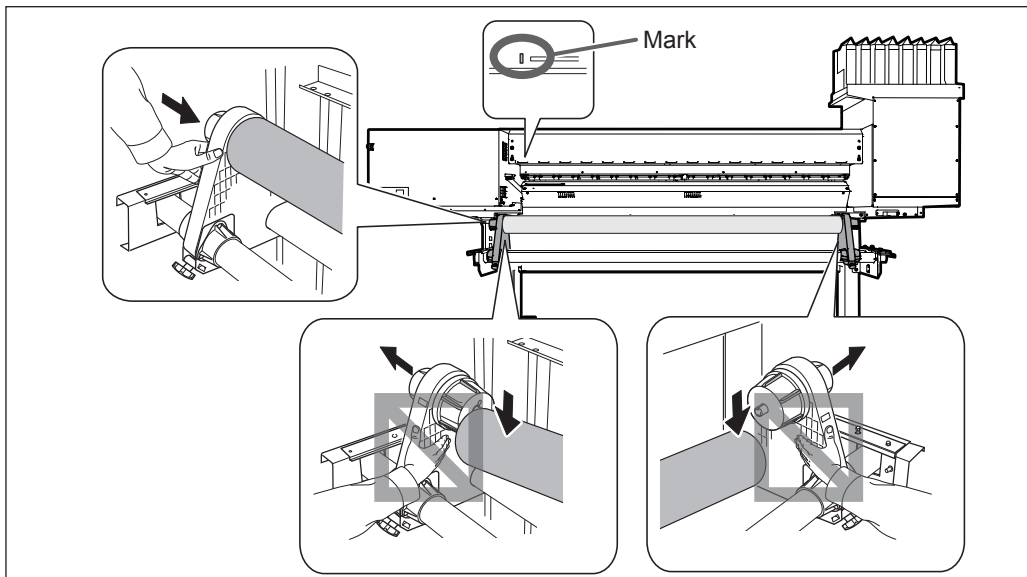

IMPORTANT! Firmly decide the left and right side positions of the media at this point.

After this procedure is completed, if the left and right side positions do not fit the proper positions when securing the media with pinch rollers, you will have to go back to this step to redo this procedure. If you attempt to forcibly readjust the position of the media simply by pulling on the media itself, printing quality will be affected due to skewed media feed.

- 5 Secure the media holder by tightening the securing screws slightly.

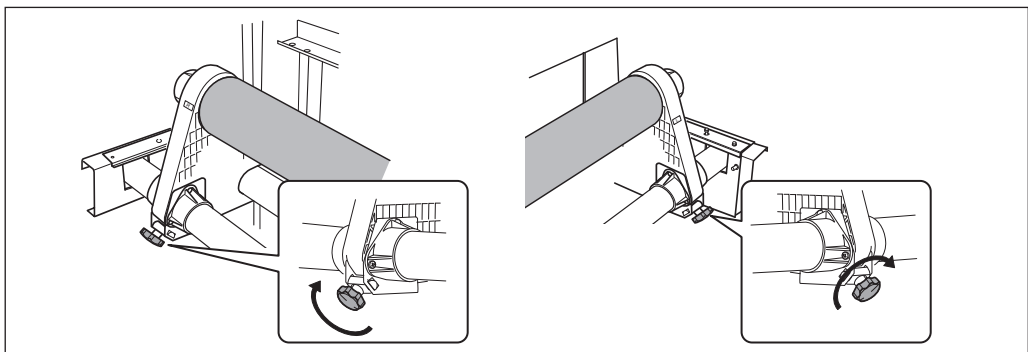

2. Pass the media through the machine and secure the media holders.

- 1 Pass the leading edge of the media between the grit rollers and the pinch rollers.
Pass the media over the top of the feed adjuster bar.

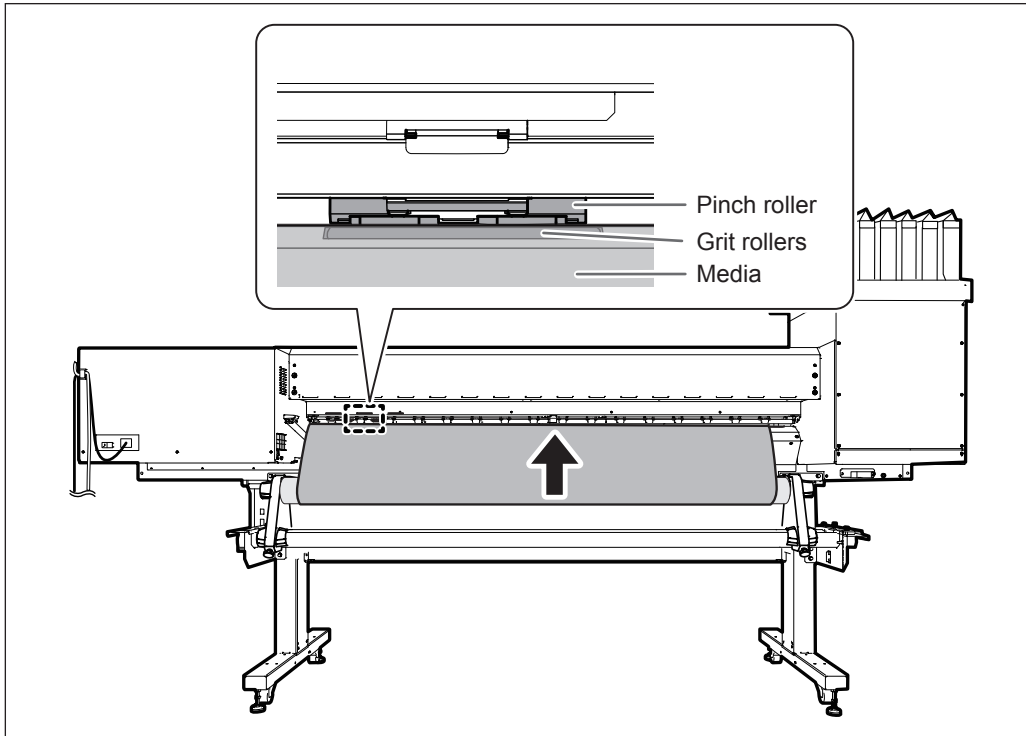

2

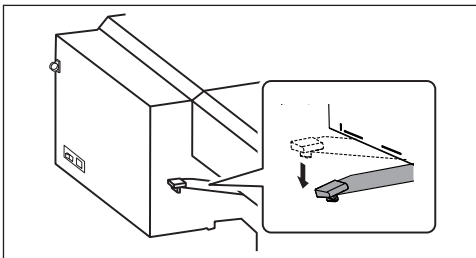

- 2 Lower the loading lever (rear).
The media is held in place.

3

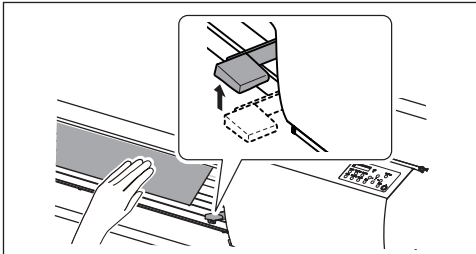

- 3 Gently hold down the media and raise the loading lever (front).
The media is released.

4 Open the front cover.

Do not open the front cover until instructed to do so.

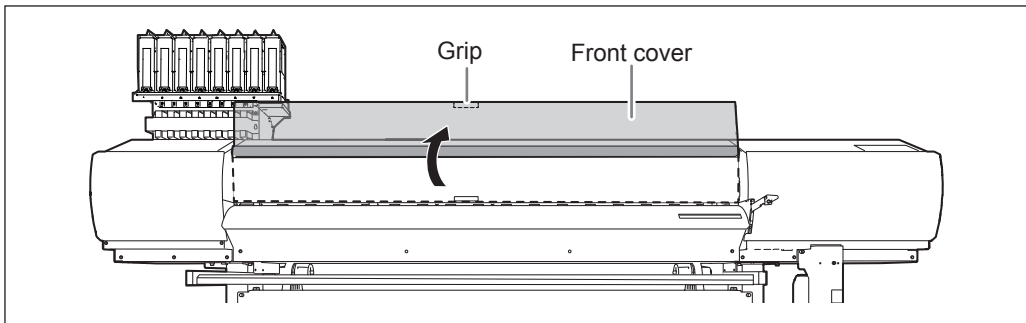
**5 Pull out the media over the platen.**

Make sure the right edge of the media is in line with the guide line.

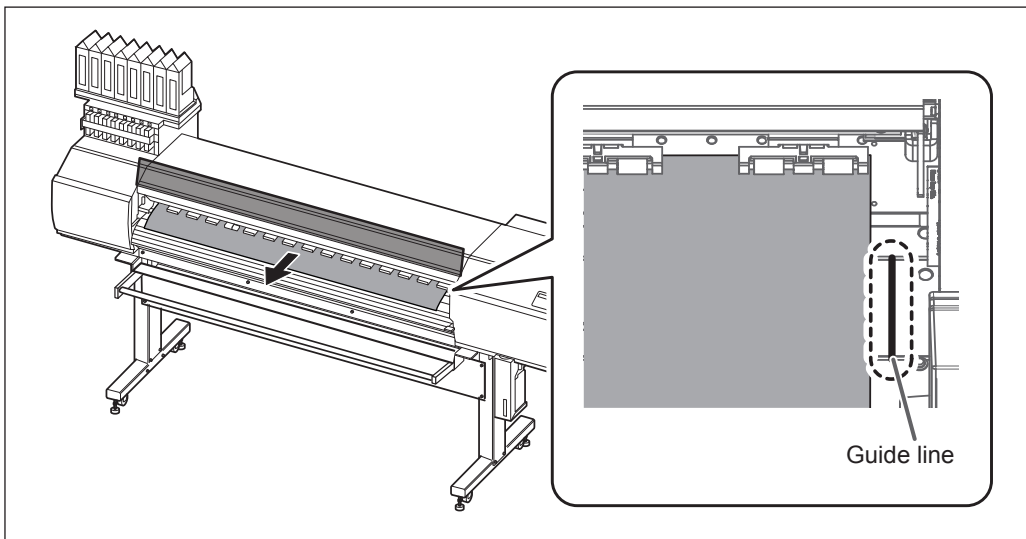
**IMPORTANT!**

If you want to readjust the media position at this point, redo the procedure from step **1-2**. If you just hold the media to readjust its position forcibly, the media will be skewed during printing, which will have an effect on the printing quality.

- 6 Hold the media at the center and pull it out, being sure to keep it straight and all areas of the media to be taut.

Make sure the right edge of the media is in line with the guide line.

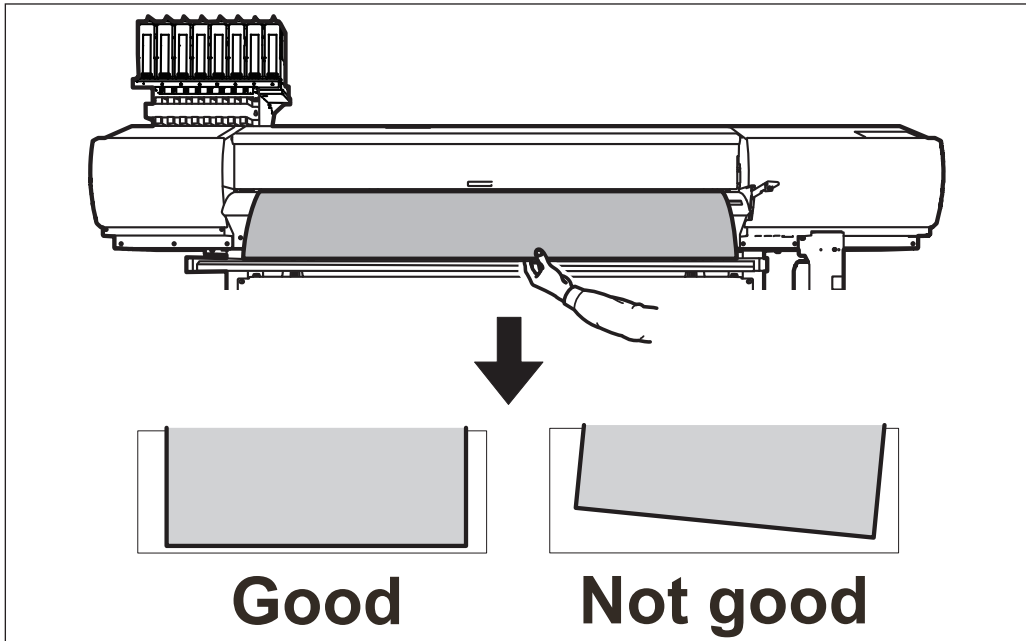

- 7

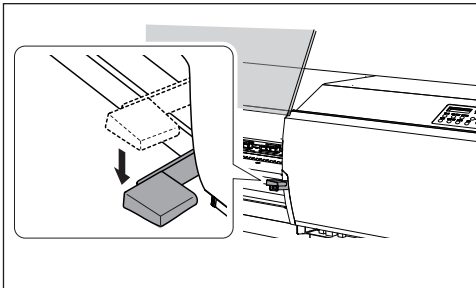

Lower the loading lever (front).
The media is held in place.

8 Clamp the edges of the media with the media clamps.

The media clamps are magnetic, and the left and right clamps are distinct. Refer to the figure and install the clamps in the correct positions, making sure not to confuse right and left.

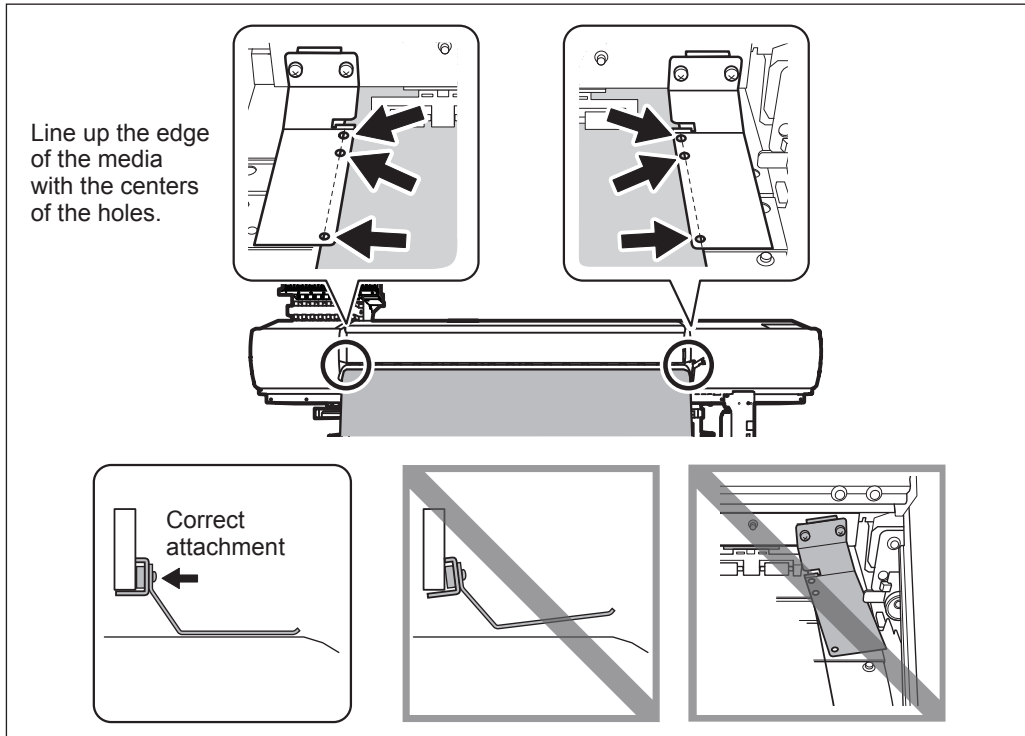
**9** Close the front cover.**10** Press **SET UP**.

The print-head carriage moves and detects the width of the media. This operation is called initialization. When initialization ends, **SET UP** lights, and the printable width is displayed on the screen. This completes the loading of the media.

IMPORTANT! Remove roll media when not in use.

If roll media is left unused in a loaded state for an extended period, the media will sag. This can cause poor printing quality and motor errors, so be sure to remove and store the media when not in use.

3. Load a paper tube onto the take-up system, and switch on the take-up system power.

This section describes parts that use the take-up system. These instructions describe how to use TUC-3. If using a take-up system other than TUC-3, refer to the user's manual of the take-up system you are using.

1 Raise the dancer roller.

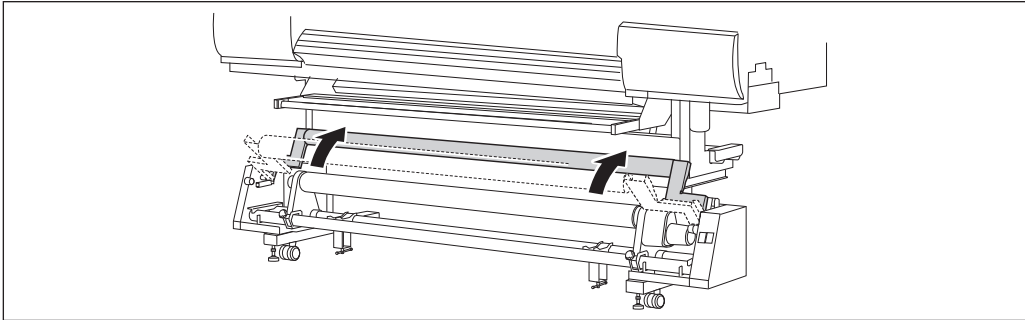

2 Lower the height of each media support to its lowest position by turning the lever.

Make sure that the media supports are on the inner side of the media holders, and turn the media support lever in the direction shown in the figure.

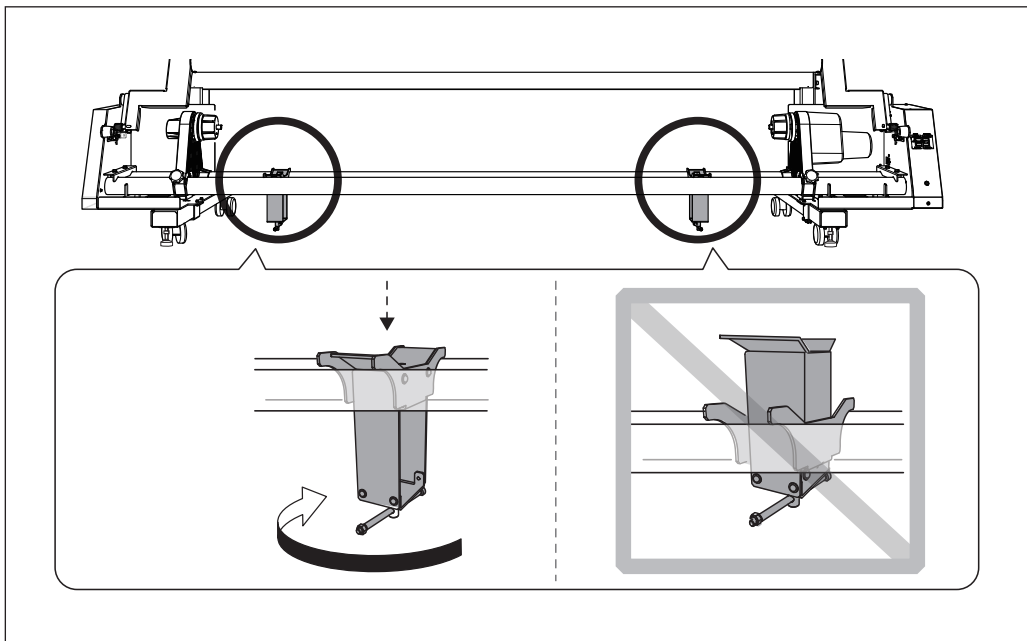

- 3** ① **Secure the motorized media holder.**
Secure the motorized media holder firmly using the securing screws.
- ② **Fit the paper tube (core) onto the end cap (Right).**
Fit the paper tube securely right to the end of the end cap.

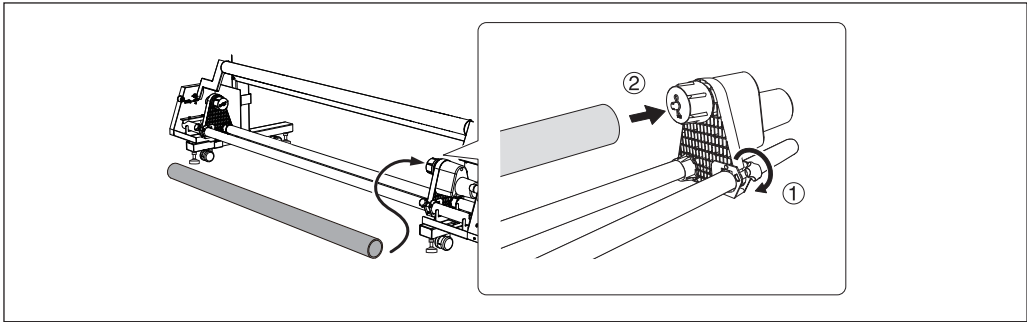

- 4** ① **Loosen the securing screw of the media holder (Left).**
② **Press the end cap (Left) against the paper tube (core) and insert it.**
Move the media holder (Left) and fit the end cap (Left) onto the paper tube (core).

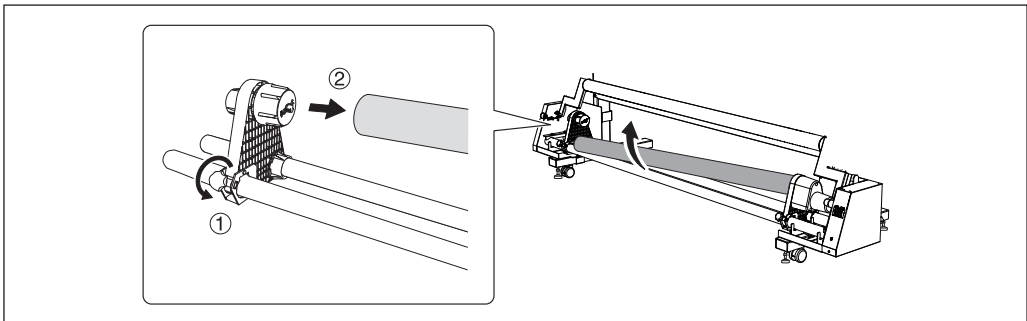
**POINT!**

Fit the paper tube securely onto the end cap. This prevents skewed feeding when the media is taken up.

IMPORTANT!

Use the paper tube that is included with the roll. If a different roll is used, the media may not be taken because the roll may fail to engage.

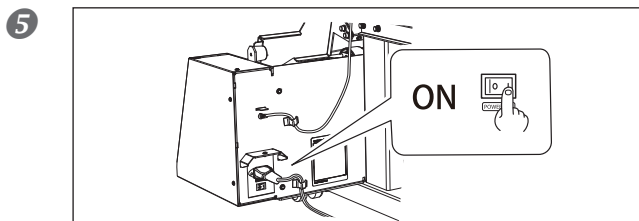

Switch on the power of the take-up system.

4. Adjust the position of the media.

1 Set the AUTO switch on the take-up unit.

POINT!

It is recommended that you use the BACKWARD setting when using the take-up unit with the machine. When using the TUC-3 as the take-up system, it is not possible to use it with the FORWARD setting if it is adjusted for use with the BACKWARD setting during installation. In the same way, it is not possible to use it with the BACKWARD setting if it is adjusted for use with the FORWARD setting during installation. To change to the BACKWARD or FORWARD setting after installation, contact your authorized Roland DG Corp. dealer.

When using the BACKWARD setting

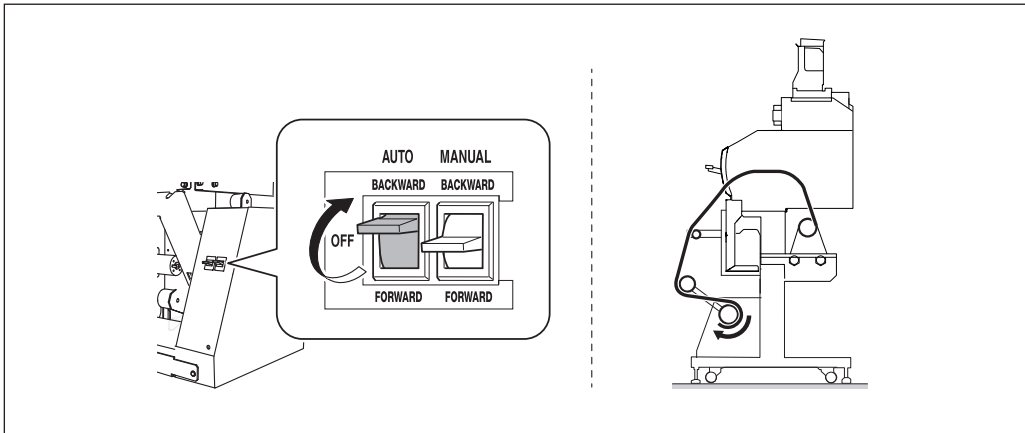

When using the FORWARD setting

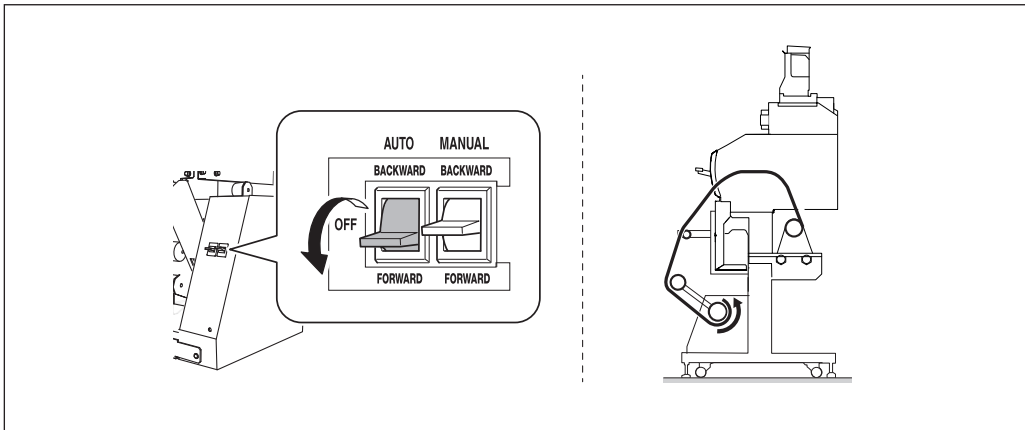

2 Close the front cover.

3

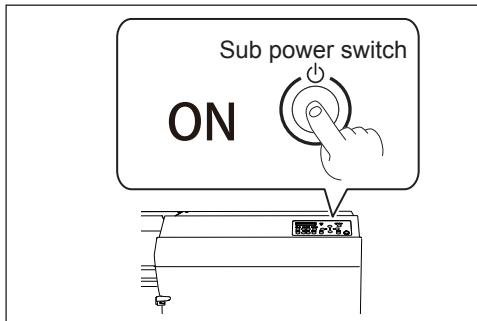
**Switch on the sub power.**

The print-head carriage moves and detects the width of the media. This operation is called initialization. When initialization ends, **SET UP** lights, and the width of the media is displayed on the screen.

4

Press  to feed out the media.

Media is fed out 1 mm (39 mil) each time you press . Holding down the key lets you feed out paper continuously.

When using the BACKWARD setting

Feed out the media until its edge just touches the floor.

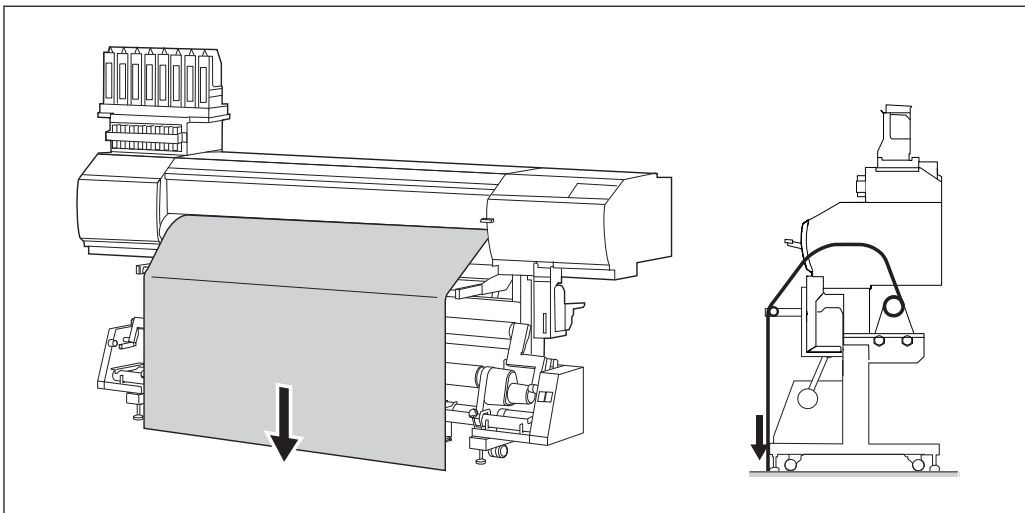
**When using the FORWARD setting**

When the edge of the media is just touching the floor, feed it out another 10 cm (3.94 in.).

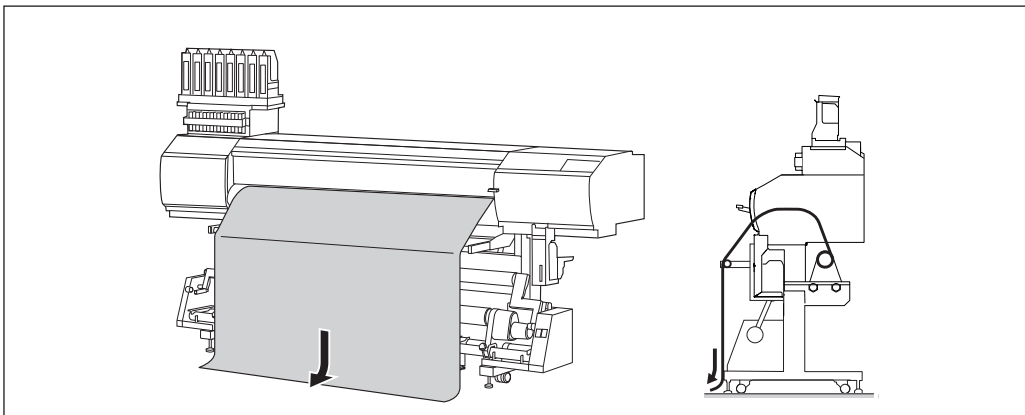

2

Basic
Operation

- 5 ① Loosen the securing screw of the motorized media holder.
② Adjust the position of the media holder.

Move both media holders so that it is possible to see around 20 mm (0.79 in.) of the paper tube (core) from the right edge of the media.

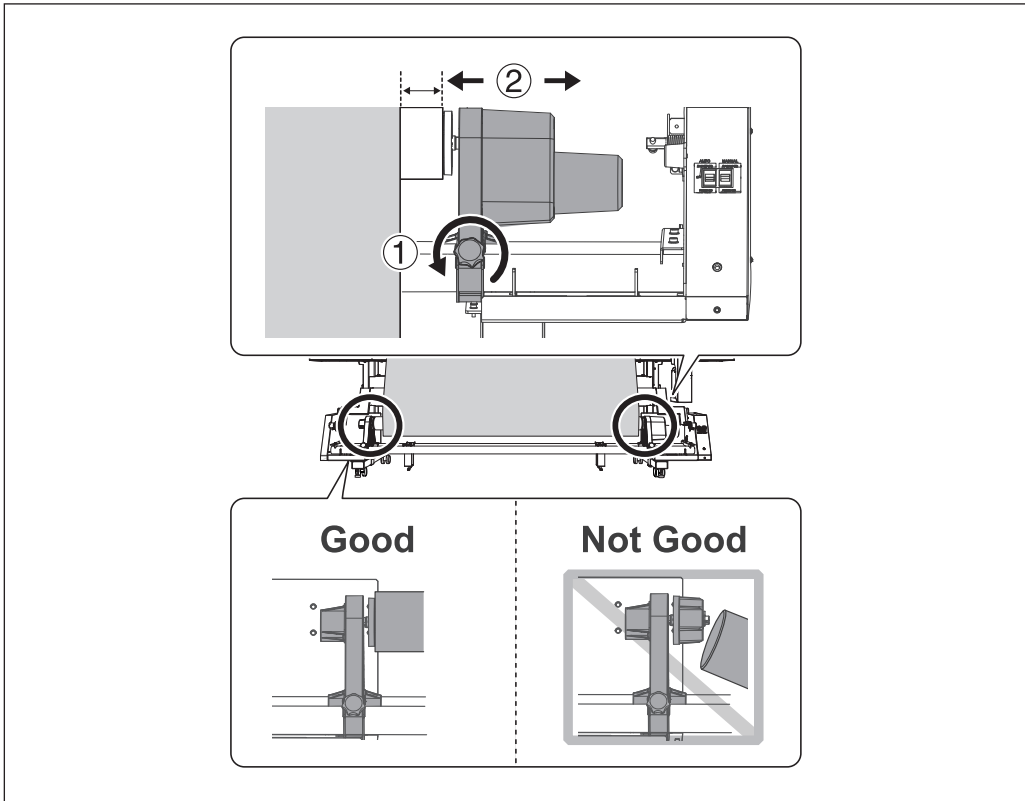

POINT!

Secure the paper tube (core) in place with the media holder at both ends so that it does not move out of position or come off the end cap.

6 ① **Secure the motorized media holder in place.**

Secure the motorized media holder firmly using the securing screws.

2 **Push the media holder (Left) in the direction of the motorized media holder and securely fasten the end cap to the paper tube (core).**

Push the media holder firmly until the gap between the media holder and end cap at either end is filled in as shown in the figure.

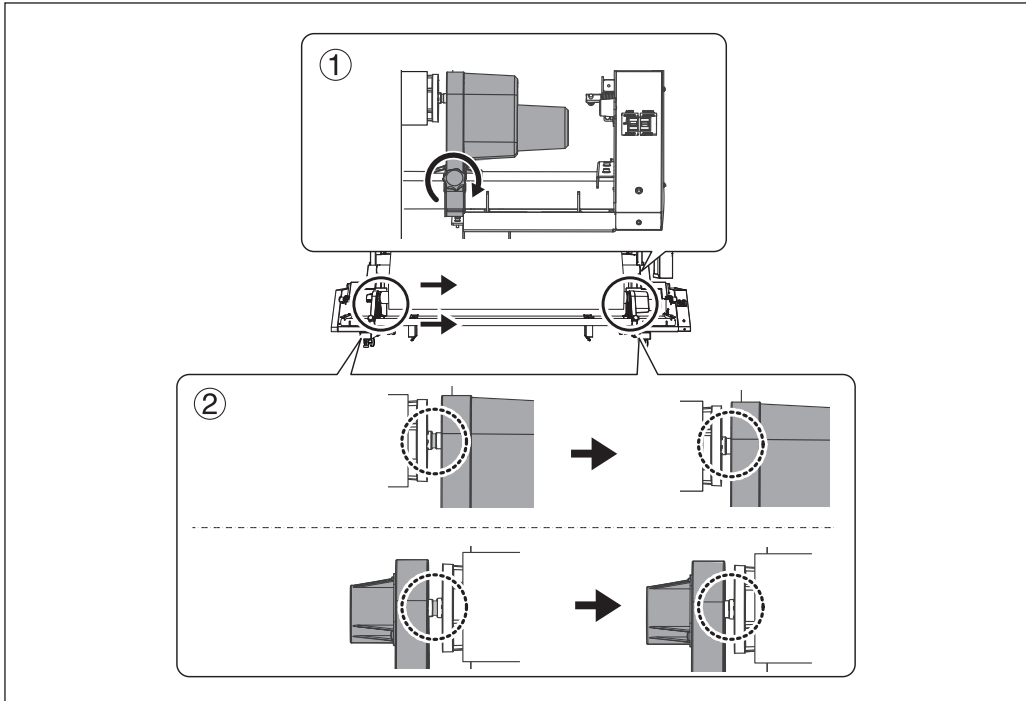
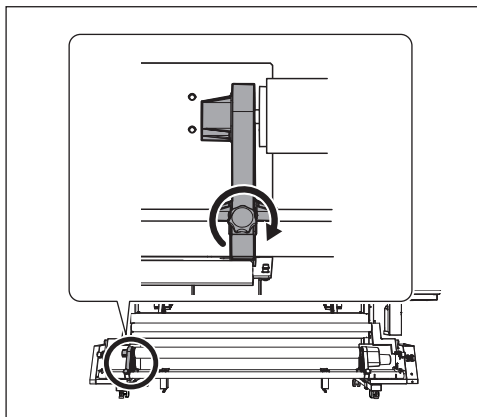
**7****Secure the media holder (Left) in place.**

Secure the motorized media holder firmly using the securing screws.

POINT!

If there is any play when the paper tube is moved from side to side, return to step ② and redo the procedure.

5. Secure the media on the paper tube (core).

1

When using the BACKWARD setting

Pass the media around the inner side of the paper tube (core).

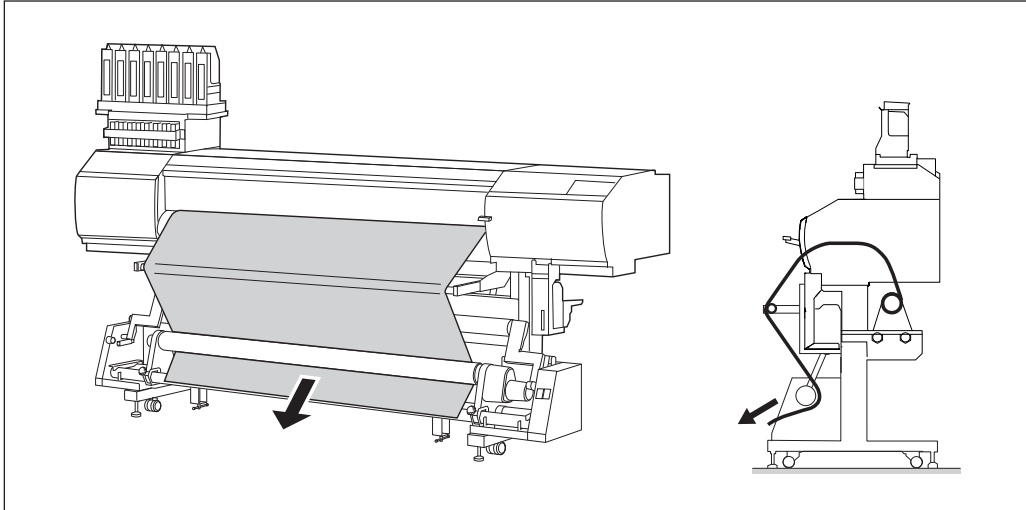

When using the FORWARD setting

Pass the media toward the back of the machine from the outside of the paper tube (core).

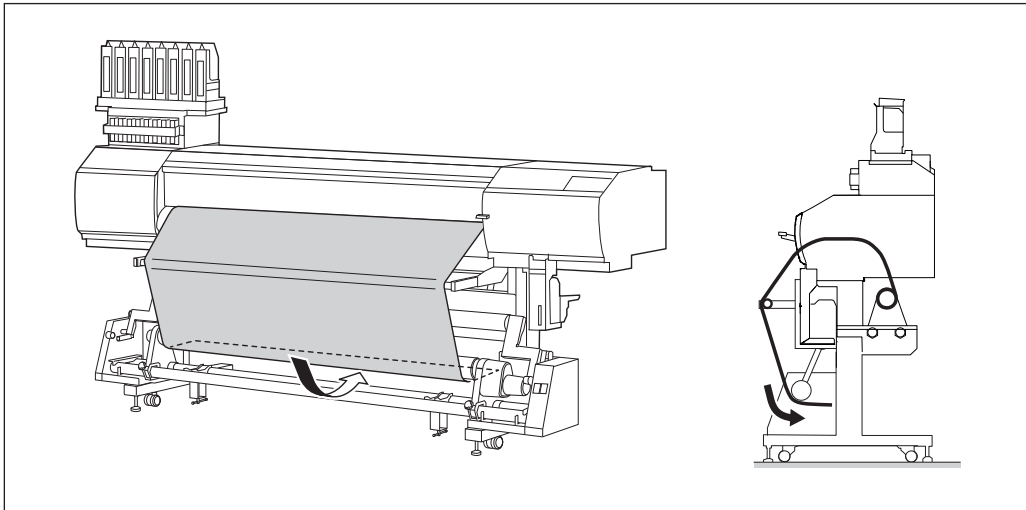

2

When using the BACKWARD setting**While holding the media, slowly lower the dancer bar forward.**

Stop lowering the dancer bar when the paper tube (core) starts rotating. When doing so, do not move the hand holding the media away. After this, you will secure the media on the paper tube (core) in this position.

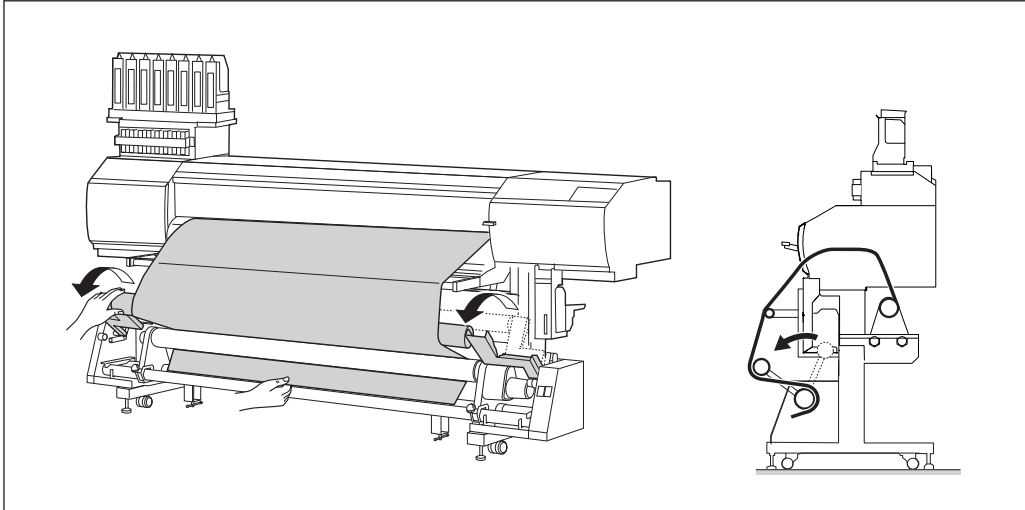
**When using the FORWARD setting****(Go round to the back of the machine and,) while holding the media, slowly lower the dancer bar forward.**

Stop lowering the dancer bar when the paper tube (core) starts rotating. When doing so, do not move the hand holding the media away. After this, you will secure the media on the paper tube (core) in this position.

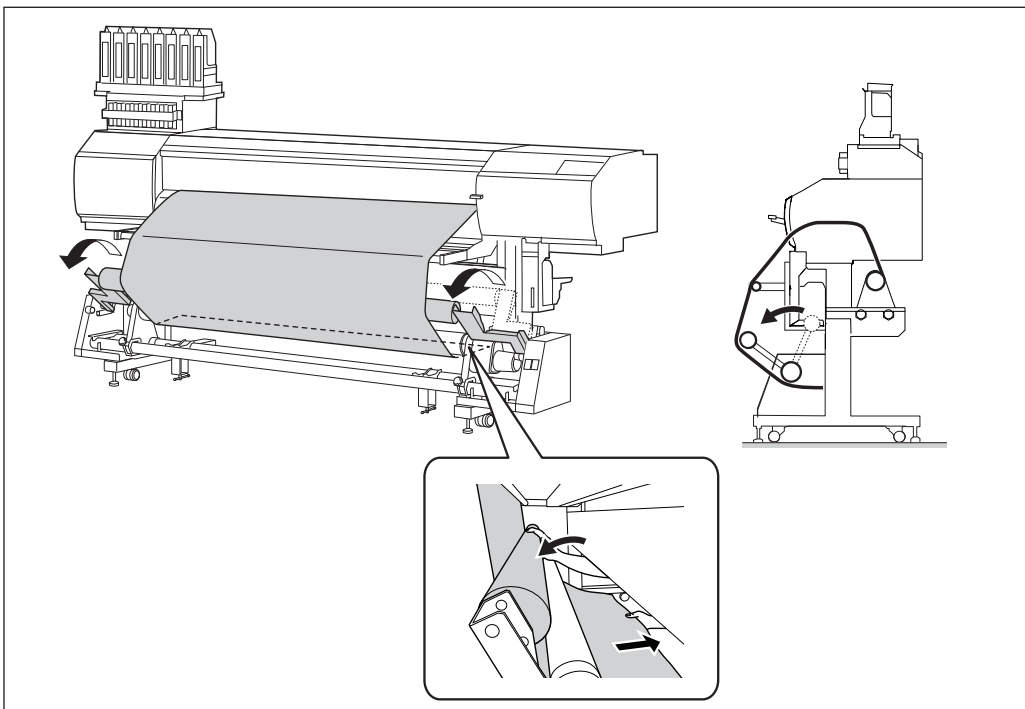

2

Basic
Operation

- 3 Attach the center and both ends of the media to the paper tube (core) using adhesive tape (three locations in total).

- ① While pulling the media so that it does not sag, secure the center of the media.
- ② While pulling the media from the center toward the outer edges, and fix the left and right edges.

When using the BACKWARD setting

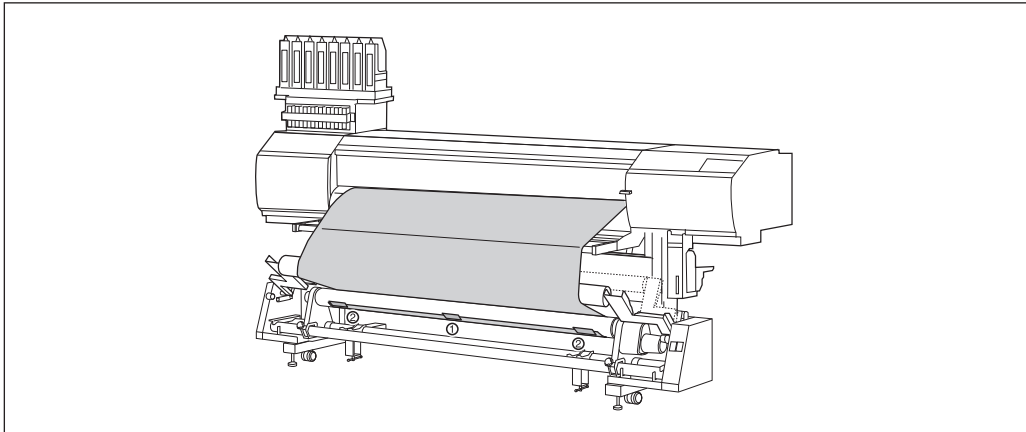

When using the FORWARD setting

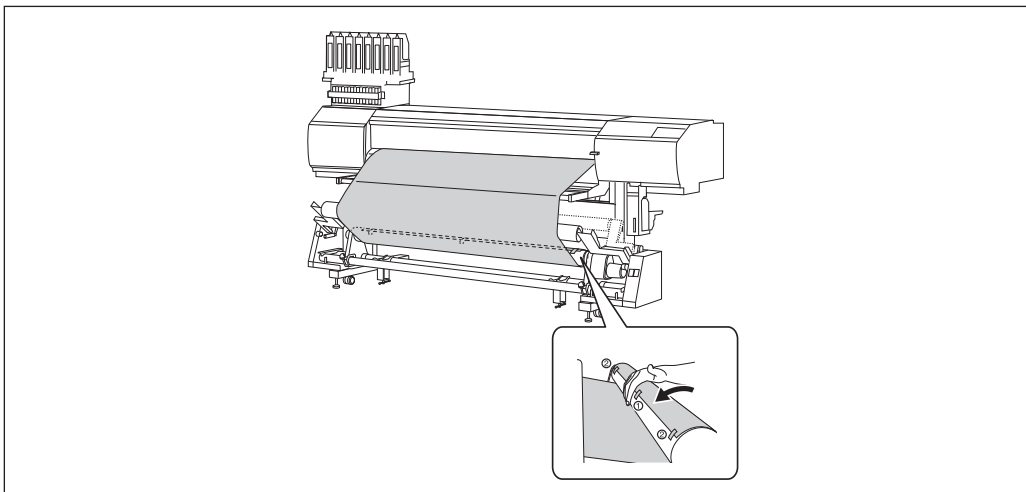

This completes the loading of the media.

IMPORTANT!

- When take-up starts, take care that the leading edge of the media does not get folded or bent.
- When the media is cut (P. 55 "Cutting Off the Media"), the media is set free. Reload the media.
- Remove when not using roll media. If roll media is left unused in a loaded state for an extended period, the media will sag. This can cause poor printing quality and motor errors, so be sure to remove and store the media when not in use.

Loading Sheet Media

Procedure

- 1 **Switch off the sub power.**
- 2 **Open the front cover.**
Do not open the front cover until instructed to do so.

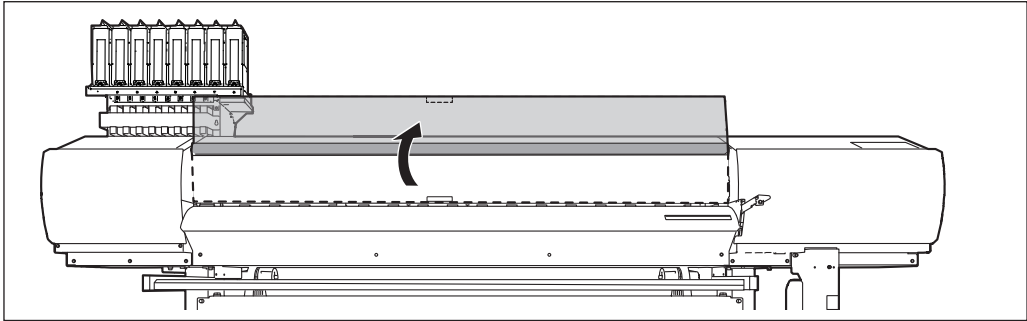

- 3 **Draw the media holders to both left and right ends respectively.**
Move them to a location where they don't disturb the media when the media is hung down from the rear of the machine. If they disturb the media, remove them along with the shaft. For information on how to remove, refer to "Setup Guide."

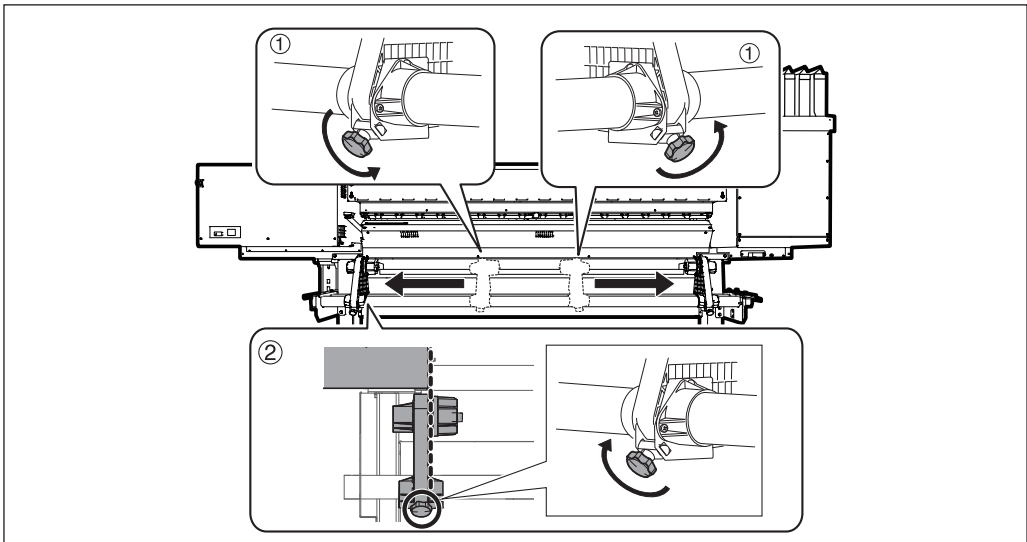

- 4 **Pass the media through the machine.**

☞ See P. 24 "Pass the media through the machine and secure the media holders." steps 2. 1 - 4

- 5** Align the front edge of the media with the location shown in the figure. Make sure the right edge of the media is in line with the guide line.

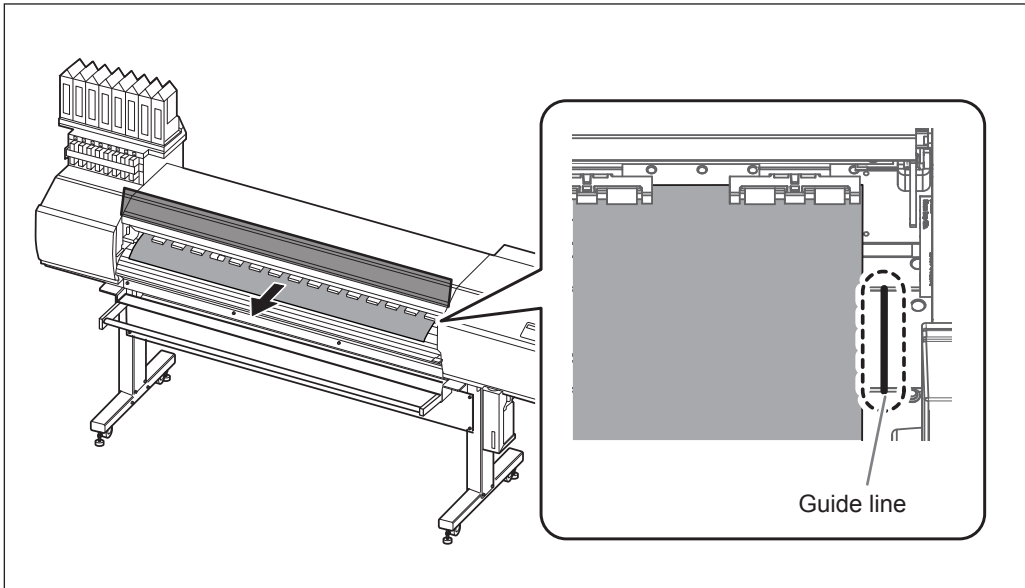

- 6** Lower the loading lever (front side) to secure the media in place.

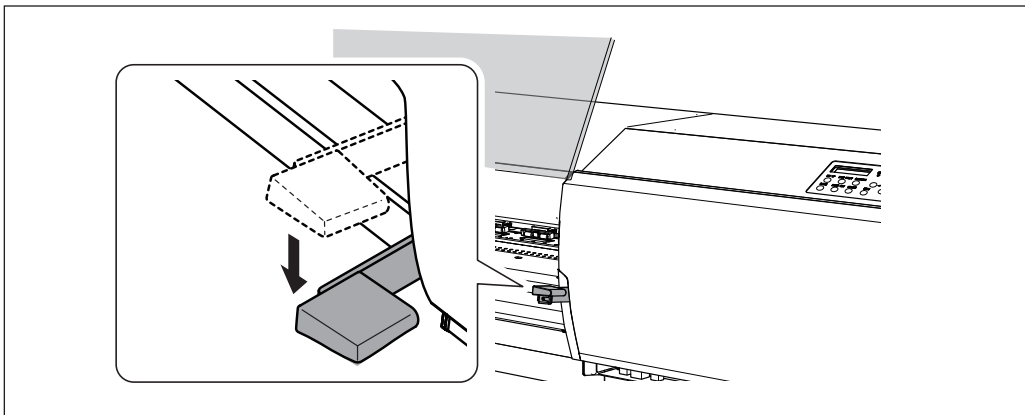

- 7**
- ① **Attach the right and left media clamps.**
 - ② **Line up the edges of the media with the centers of the holes of the media clamps.**
- The media clamps are magnetic, and the left and right clamps are distinct. Refer to the figure and install the clamps in the correct positions, making sure not to confuse right and left.

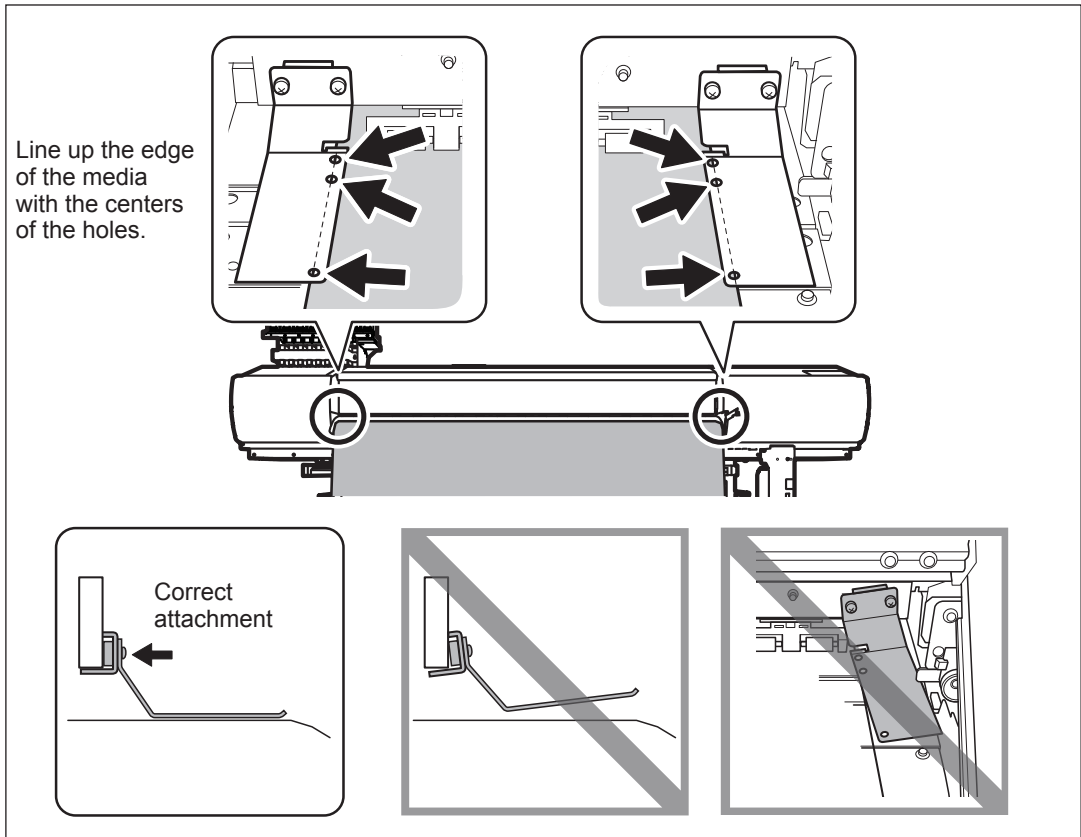

- 8** **Load the media onto the take-up system.**
- ☞ See P. 28 "Load a paper tube onto the take-up system, and switch on the take-up system power." to P. 34 "Secure the media on the paper tube (core)."

Performing the Initial Adjustment (Correcting for Misalignment in Bidirectional Printing More Precisely)

Perform the initial adjustment of this machine. This adjustment must be performed in the following cases:

- When using this machine for the first time
- When changing the media to use
- When printing is not improved by performing simple correction for bidirectional printing (P. 102 "Correcting for Misalignment in Bidirectional Printing")

1. Print a test pattern.

1 Press **MENU**.

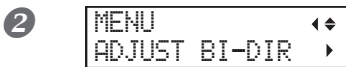

Press **▼** several times to display the screen shown on the left.

Press **▶**, then **▲**.

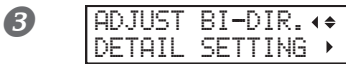

Press **▶**.

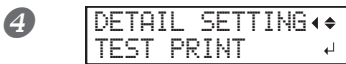

Press **ENTER**.

A test pattern is printed.

When printing ends, press **▼**.

2. Read the correction values from the test pattern.

Choose the value that produces the least misalignment of the 2 lines. When you cannot choose between two numbers, select a value that is halfway between them.

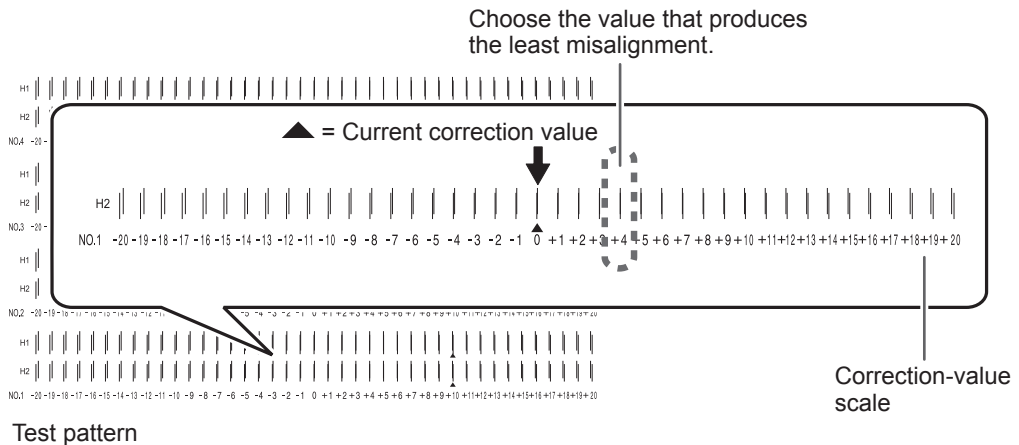

3. Enter the correction values that you read.

Enter the corresponding correction values for H1 and H2.

①

DETAIL SETTING ◀▶
SETTING NO.1 ▶

Press .

②

H2 H1 ◀▶
1 1 ▶

Press  or  to select H1 or H2.

Press  or  to select the correction value.

Select the correction values that you read in step 2.

When you have finished setting the correction values,

press .

This completes the configuration of [SETTING NO. 1]. Next, press  and set the correction values for [SETTING NO. 2] to [SETTING NO. 4] in the same manner.

③ Press , then  to go back to the original screen.

Setup of Media

About "MEDIA SETTING" menu

To ensure the optimal printing according to the media size and type, various setting items are provided in the machine. The machine provides the "MEDIA SETTING" menu that guides you through these settings in an interactive mode. Using this menu, you can set all of the basic settings simply by following the instructions on the display.

Since setting details can be stored as a preset menu, you can work efficiently by skipping the setup procedure when using the same type of media. Once the basic settings have been stored in a preset, fine adjustments can be made as necessary.

The items set through the "MEDIA SETTING" menu can be also set individually.

Setup of Media ("MEDIA SETTING" menu)

Note: If a setting is not necessary, you can go to the next menu by selecting [NEXT].

1. Start the "MEDIA SETTING" menu.

1 Load media.

Check that the media is not sagging. If any sagging exists, the following correction value settings will not function effectively.

☞ P. 21 "Loading Media"

2 Press **MENU**.

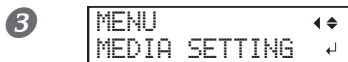

When the screen shown on the left is displayed, press **ENTER**.

To cancel setup

Procedure

1 Press **MENU** during setup.

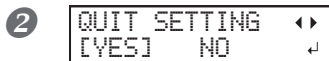

Press **←** to select [YES].
Press **ENTER**.



The screen on the left appears again.
Selecting [NO] returns you to the screen that was displayed when you pressed **MENU**.

2. Set the dryer temperature.



Press or to set the temperature.

Recommended temperature: 40°C

Press to confirm your entry.

For the individual setting method and the description of this setting item, refer to the following section.

☞ P. 98 "Setting the Temperature of the Dryer"

To cancel setup

Procedure

1 Press during setup.

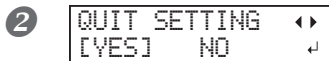

Press to select [YES].

Press .

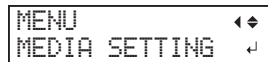

The screen shown in the figure on the left appears again. Selecting [NO] returns you to the screen that was displayed when you pressed .

3. Adjust the print head height.

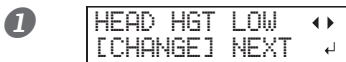

Press to select [CHANGE].

Press to confirm your entry.

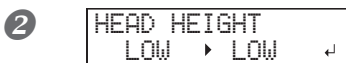

When the screen shown on the left is displayed, open the front cover.

3 Move the height-adjustment lever to adjust the print head height.

When the lever is moved to the "High" direction, the buzzer sounds twice. When it is moved to the "Low" direction, the buzzer sounds once.

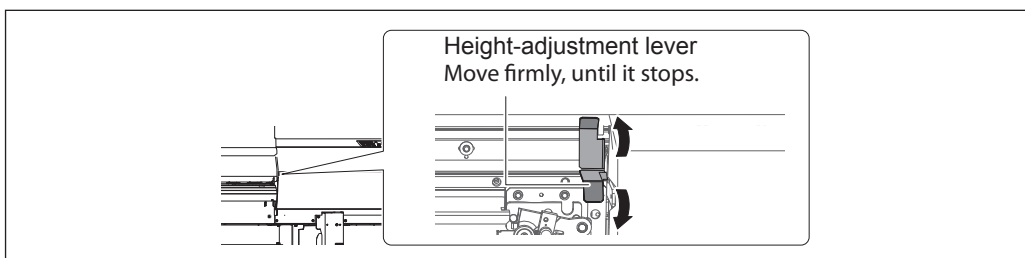

POINT!

Normally move the height-adjustment lever to "Low." For media that is wrinkled or comes loose from the platen, move the height-adjustment lever to "High."

4 Close the front cover.

For the individual setting method and the description of this setting item, refer to the following section. P. 106
 "Adjusting Print Head Height to Match Media Thickness"

4. Perform position correction of the feed direction (reduce horizontal stripes).

POINT!

Feed direction means the feed direction of the media. Perform correction adjustments to the media in advance because horizontal stripes are more likely to occur during printing when the movement distance of the media changes subtly depending on the media type or thickness.



Press to select [SET].
 Press to confirm your entry.

The test pattern of feed correction is printed.

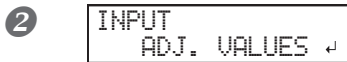

When the screen shown on the left is displayed, press .

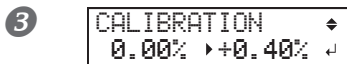

Use and to set the correction value.
 Press to confirm your entry.

Current correction value Value to be set

To decide a correction value

Select the value to make the upper/lower rectangular gap and overlap smallest. When you cannot choose between two numbers, select a value that is halfway between them.

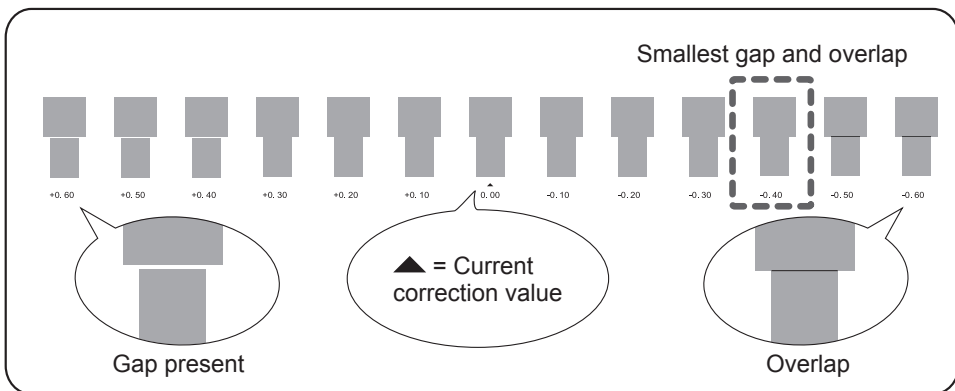

4

```

REDD ADJ.?  <>
[LYES]  DONE  ↵
  
```

To confirm again/adjust again

Press to select [YES].

Press to confirm your entry.

The test pattern of feed correction is printed again. Go back to step 3 and set again.

To go to the next after correction is completed

Press to select [DONE].

Press to confirm your entry.

For the individual setting method and the description of this setting item, refer to the following section. P. 103 "Reducing Horizontal Bands (Feed Correction Function)"

5. Perform correction for misalignment in bidirectional printing.

POINT!

This machine prints by the bidirectional mode (in which the print-head carriage performs printing during both its outbound pass and return pass). This printing method is called "Bidirectional Printing." This method offers the advantage of being able to shorten printing times, but subtle misalignment occurs during the outbound and return passes. The procedure to correct this and eliminate misalignment is "Bidirectional Correction."

1

```

ADJUST BI-DIR. <>
[SET]  NEXT  ↵
  
```

Press to select [SET].

Press to confirm your entry.

The test pattern of bidirectional correction is printed.

2

```

INPUT
ADJ. VALUES ↵
  
```

When the screen shown on the left is displayed, press

.

3

```

ADJUST BI-DIR. <>
  0  >  6  ↵
  
```

Use and to set the correction value.

Press to confirm your entry.

Current correction value

Value to be set

To decide a correction value

Choose the value that produces the least misalignment of the 2 lines. When you cannot choose between two numbers, select a value that is halfway between them.

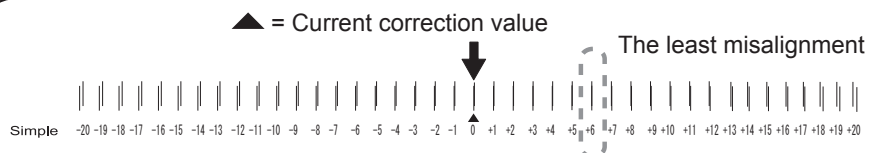

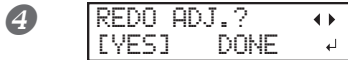

To confirm again/adjust again

Press to select [YES].

Press to confirm your entry.

The test pattern of bidirectional correction is printed again. Go back to step **3** and set again.

To go to the next after correction is completed

Press to select [DONE].

Press to confirm your entry.

For the individual setting method and the description of this setting item, refer to the following section. P. 102
"Correcting for Misalignment in Bidirectional Printing"

6. Set the drying method and time after printing.



Press or to select a value.

Press to confirm your entry.

POINT! Drying method after printing

Set whether the media should be fed until the trailing edge of the printed area is put on the dryer after the 1st page is printed. To make sure to dry the entire printed area, select "ENABLE". If "DISABLE" is selected, the trailing edge of the printing area is not fed to the dryer unless you continue with a subsequent printing operation.

For the individual setting method and the description of this setting item, refer to the following section. P. 100
"Drying the Trailing Edge of the Printing Area on the Dryer"

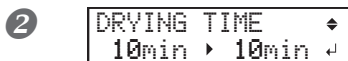

Current setting

Setting after change

Press or to set the drying time.

Example of setting time (general guide)

Note: The setting time varies according to the settings such as the type of media and the printing quality.

Condition: Non-coated vinyl chloride media

Setting time: About three minutes

Press to confirm your entry.

POINT! Drying time after printing

Set the drying time after the 1st page is printed. The next operation is not started until the set time passes.

For the individual setting method and the description of this setting item, refer to the following section. P. 101
"Setting the Drying Time after Printing"

7. Save the setting as preset.

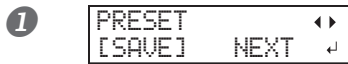

Press to select [SAVE].

Press to confirm your entry.

If you select [NEXT], the screen in step 4 is displayed, and the settings you have selected up to this point are not saved as a preset. However, they will remain as the current settings values for the machine.

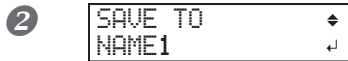

Press or to select a destination to save the preset.

You can select a name from NAME1 to NAME8.

Press to confirm your entry.

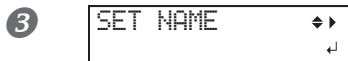

Press or to select a character.

Press to move to the next character.

Select the following characters in the same way.

You can enter up to 15 characters.

Press to confirm your entry.



Press to go back to the original screen.

For the individual setting method and the description of this setting item, refer to the following section. [P. 94](#)
"Fully Utilizing the Preset Function"

This completes the operation of the "MEDIA SETTING" menu.

Setting the Printing-start Location

The output-start location can be set to any location you desire. (It is possible to print even if this setting is not configured.) Note, however, that this setting must be made for each individual page. When the printing of one page finishes, the output-start location returns to its default value.



POINT!

Note that the left and right positions are not restored to their defaults for test patterns.

Procedure

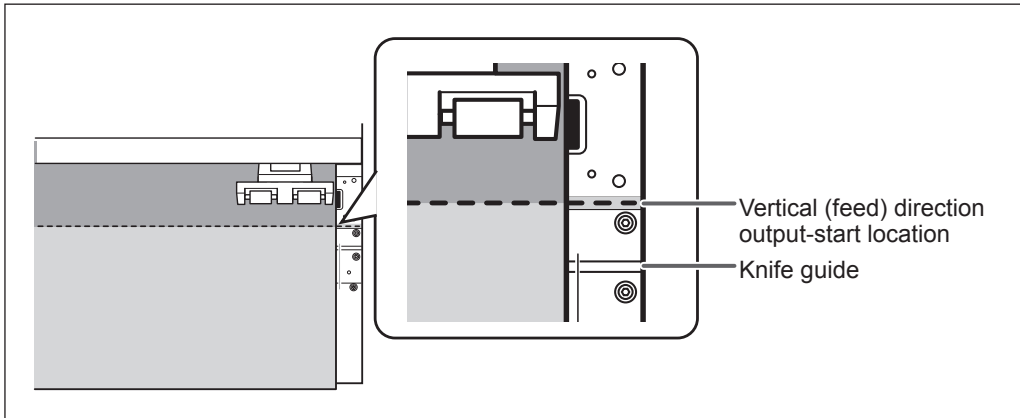
- 1 Set the output-start location in the vertical (feed) direction by pressing  and  to move the media.



- 2 Set the output-start location in the horizontal (scan) direction by pressing  and  to move the print heads.

When a cursor key is pressed, preparations for moving the print heads are started. When the preparations are finished, move the print heads.

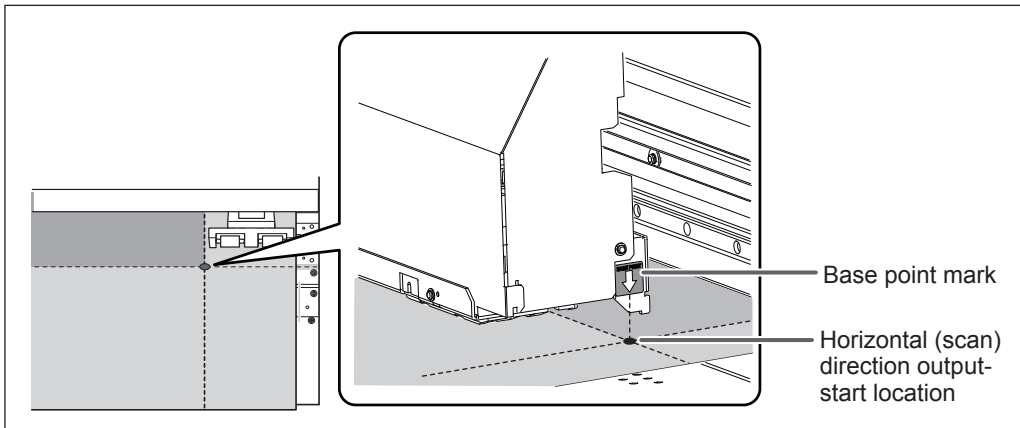

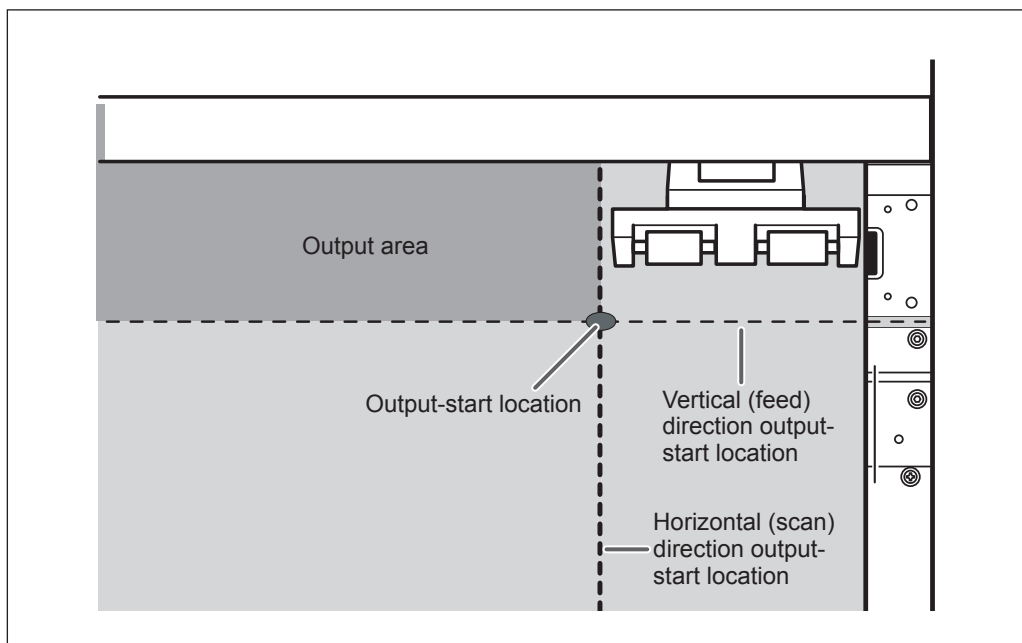

- 3 When the location is set, press **BASE POINT**.

```
W1100mm
B
```

BASE POINT lights. When the screen displays the character "B" together with the output-possible width at the location, setting is complete.

Printing Tests and Normal Cleaning

Before you carry out actual printing, perform a printing test to ensure no dot drop-out occurs. If dot drop-out occurs, perform cleaning of the print heads (normal cleaning).

1. Setting a test print direction

* The factory default setting of the test print direction is "FEED." When performing printing tests successively, you can select "FEED" or "SCAN" as the print direction applied to the second and later tests. However, when the optional media take-up system is used, "Feed" is applied regardless of the setting of the test print direction.

☞ P. 115 "Using the Media Take-up System"

- 1 Press **MENU**.

```
MENU      ◀▶
SUB MENU  ▶
```

Press **▼** several times until the screen on the left appears.

Press **▶**.

```
SUB MENU  ◀▶
TEST PRINT POS ▶
```

Press **▼** several times until the screen on the left appears.

Press **▶**.

- 4  Press   to select "SCAN."
Press  to enable the setting.
- 5 Press  to go back to the original screen.

2. Perform a printing test

1 Setting the Print-start Location.

☞ P. 48 "Setting the Printing-start Location"

POINT!

When performing the tests successively, you don't need to set the print-start location for the second and later tests. However, if one of the followings is conducted, the default print-start location takes effect. Set the desired print-start location again as necessary.

- Cutting of sheet
- Printing of data you created
- Cancellation of media loading

2 Hold down for one second or longer.

A test pattern is printed.

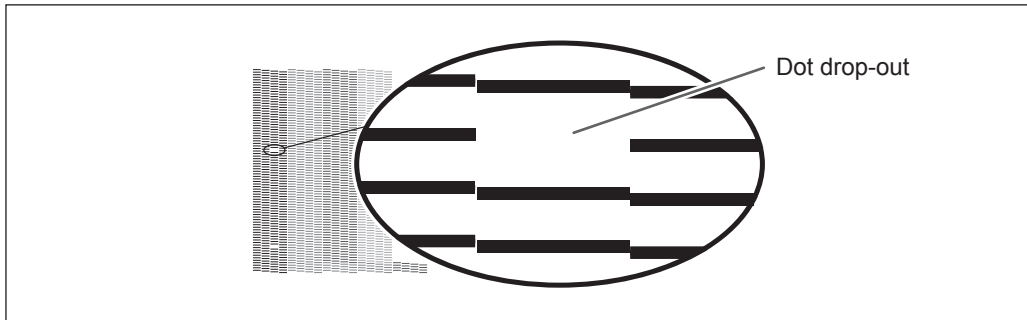

3. Perform a normal cleaning

1 Press .

2 Press .

3 Check for the group with dot drop-out by viewing the printing-test results.

With normal cleaning, only the group of print heads having dot drop-out is cleaned.

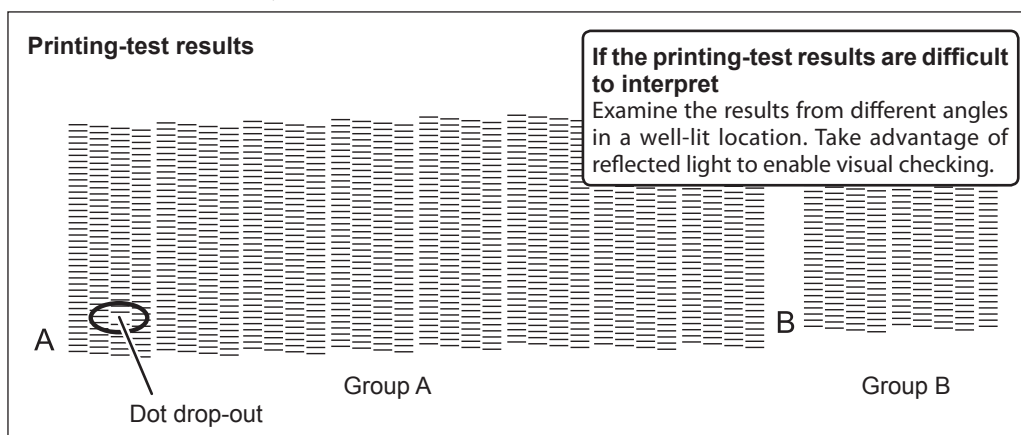

4

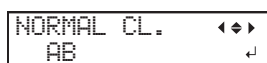

Press or to select the group of print heads that is not to be cleaned.

Press or to get rid of the group display. Repeat this process to display only the group of print heads that requires cleaning.

The only groups that can be cleaned are those that are displayed as A or B.

5

Press .

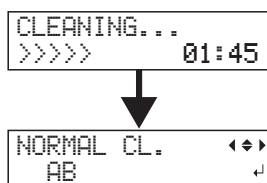

The screen shown in the figure appears, and then cleaning starts.

The (approximate) remaining time for the procedure is displayed on the screen. ("01:45" = "1 minute and 45 seconds")

When cleaning finishes, the screen shown in the figure appears again.

6

Press , then to go back to the original screen.

7

Perform a printing test again to make sure the dot drop-out has been corrected.

If the problem persists, try performing cleaning again. If the printer has been used for a long period, the problem may not be fixed even after performing cleaning two or three times. If the problem doesn't go away, try cleaning using a different method.

☞ P. 67 "When Normal Cleaning Is Not Effective"

When You Want to Clean All Print Heads Simultaneously

Hold down for one second or longer. Cleaning for all print heads starts automatically.

Getting Ready to Receive Data from a Computer

When P. 21 "Loading Media" and P. 42 "Setup of Media" are completed, get the machine ready to receive the data from the computer.

⚠ CAUTION

Never touch the print-head carriage while printing is in progress.

The print-head carriage moves at high speed. Coming into contact with the moving carriage may cause injury.

Procedure

- 1 Close the front cover.
- 2 Check that **SET UP** is lit.
If it is not lit, lower the loading lever and press **SET UP**.
- 3 Wait until **HEATER** stops flashing and stays lit.
- 4 Check that the top menu is displayed.
If the top menu is not displayed, press **MENU** several times.

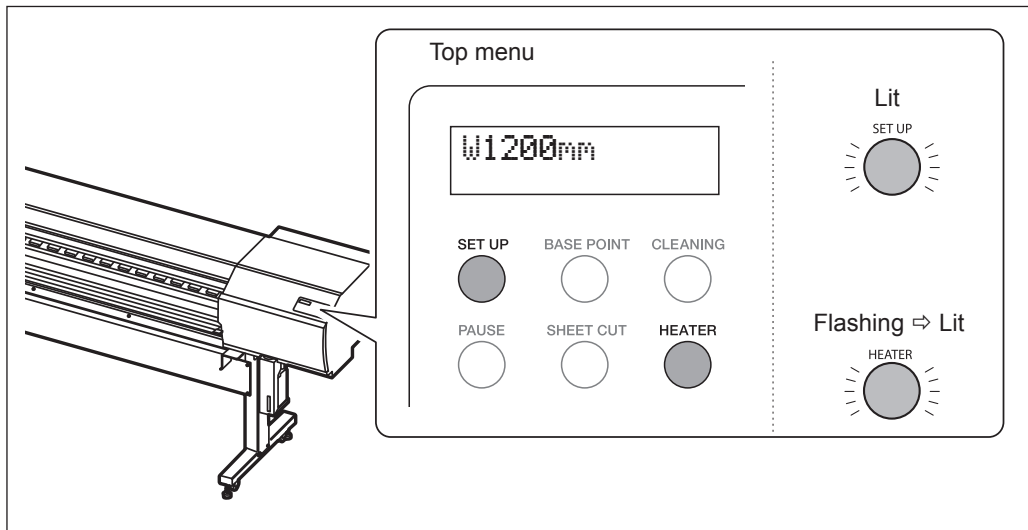

POINT!

Printing is not possible in these situations

- The machine does not run when a cover (front, left, or right) is open.
- Never open a cover (front, left, or right) while printing is in progress. Doing so interrupts printing.
- Data from the computer is not accepted when **SET UP** is dark.
- Printing does not start until **HEATER** lights. (If the dryer is set to "OFF," printing is possible even if **HEATER** is not lit.)
- Data from the computer is not accepted when you are not at the top menu.

Starting Printing

When P. 52 "Getting Ready to Receive Data from a Computer" is completed, it is possible to start printing. To print, the following procedure is required

① Creating printing data

Create printing data using application software such as Adobe Illustrator. For information on how to create the data, refer to the documentation of your application software.

② Sending the output data to this machine using the software RIP

For information about installing and using the software RIP, refer to the documentation for the software RIP.

IMPORTANT!

Points that must be observed when printing

- When performing printing, be sure to attach the media clamps. Otherwise, the edges of the media may warp and catch on the print heads.
- Do not touch the media during printing. Doing so may obstruct media feed or cause the media to rub against the print heads, which may result in a paper jam or damage to the heads.
- Keep the loading lever raised when the machine is not in use.

Remaining Ink during Printing

Ensure there is sufficient remaining ink

When the ink in the sub tanks runs out (or, if using 4 colors, when all ink of the same color runs out) during printing, printing pauses. When printing pauses, the coloring at the seam may be altered when printing resumes. Before performing printing, check the amount of ink remaining in the ink pouches by examining them to see how full they are. Take care particularly when performing lengthy printing.

☞ P. 60 "Out-of-ink Warnings", P. 61 "Ink Pouch Replacement"

If a Cover Opens during Operation

If the front cover, left cover, or right cover (hereafter collectively referred to as “covers”) is opened during printing or any other operation where the print-head carriage (hereafter referred to as “carriage”) is moving, the machine will perform an emergency stop.

When an emergency stop occurs, a message requesting the covers be closed will be displayed on the screen. Close the covers as directed in the instructions shown on the screen.

After closing the covers, the following message appears on the screen. Press **ENTER** as directed in the instructions shown on the screen. Once recovery from the error is complete, you will be able to continue working.

```
PRESS THE ENTER
KEY TO CONTINUE
```

If the above message does not appear even after closing the covers, it may be that an unrecoverable error has occurred. Refer to P. 142 "An Error Message Appears" for details.

Pausing or Canceling Printing

You can pause and cancel printing before it finishes. We do not recommend resuming printing because horizontal bands are produced at the place where printing was paused.

Procedure

- 1 Press **PAUSE** during printing.

Printing operation is paused.

- Press **PAUSE** again to resume printing.

To cancel printing, go the next procedure without pressing **PAUSE** at this stage.

- 2

```
TO CANCEL, HOLD
DOWN SETUP KEY
```

When the screen shown in the figure appears, hold down **SET UP** for one second or longer.

The printing operation is canceled.

- 3 Stop sending the data from the computer.

Cutting Off the Media

Procedure

- 1 Remove the left and right media clamps.

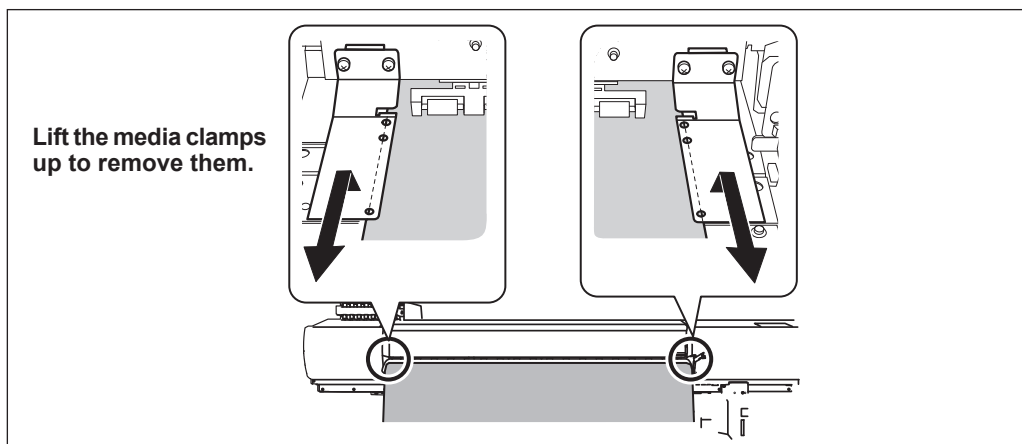

- 2 Close the front cover.
- 3 Check that **SET UP** is lit.
- 4 Hold down **SHEET CUT** for one second or longer.
The media is cut off.

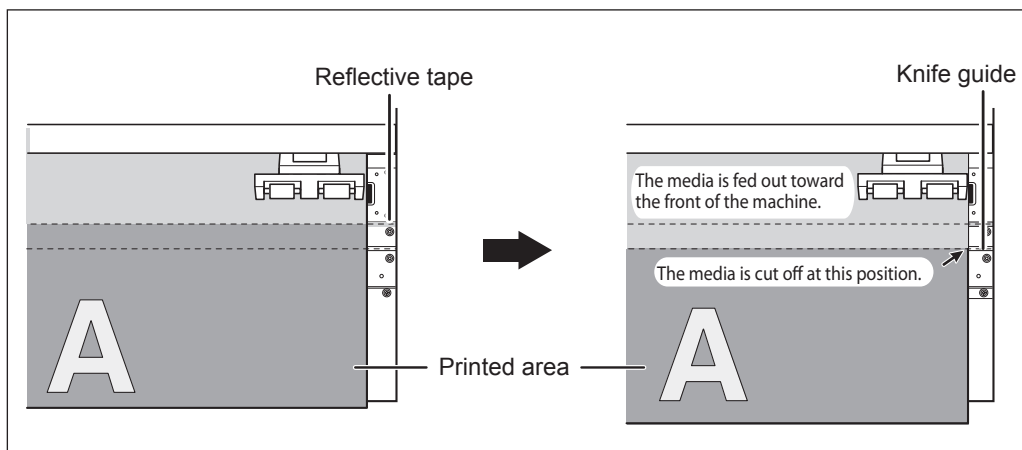

It is possible to configure the settings in the software RIP for automatic media cutoff after printing has finished. For information on how to configure the settings, refer to the documentation for the software RIP you are using.

IMPORTANT! Cutoff Operations

When the media clamps are attached, the screen shown on the left appears. Open the front cover, remove the left and right media clamps, and then press **ENTER**.

- Be sure to remove the media clamps. If you attempt to perform the cutoff operation while the media clamps are attached, the machine will detect them and interrupt the operation.
- Even if you enable the automatic media-cutoff function in the software RIP, if the media clamps are attached, the machine will detect them and interrupt the operation.
- When performing cutoff, do not use **▲** to pull the media back. Unless the end of the media has been pulled out to a location to the front of the platen, cutoff may not be performed smoothly.

IMPORTANT! Give attention to the media composition

- For some types of media, cutoff is not possible.
- Some types of media may remain on the platen after cutoff. If the media remains on the platen, remove it by hand.

Transfer conditions

Recommended Transfer Conditions (Ink: genuine Roland DG ink compatible with the machine)

Heat bonded at 200°C (392°F) for 60 seconds

Note: Transfer conditions for materials other than cloth may differ from the above.

Other Points to Remember

To ensure stable transfer quality, we recommend waiting for at least 1 hour after printing before transferring. Insufficient dry time may result in a reduction in quality.

Switch Off

Switch Off

⚠️ WARNING

When output is not being performed, remove any loaded media or switch off the sub power.

The continued application of heat at a single location may cause the release of toxic gases from the media or pose a fire hazard.

Procedure

1

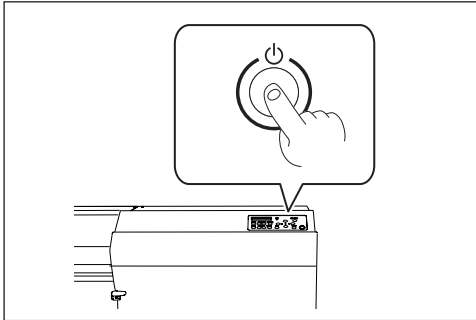

Switch off the sub power whenever printing is finished.

Hold down the sub power switch for one second or longer.

2

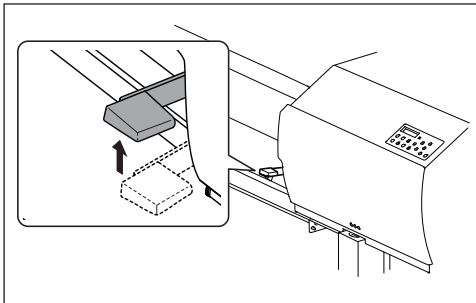

Raise the loading lever and remove the media.

When not using the machine, raise the loading lever even if the sub power is on.

IMPORTANT!

Leave the main power switched on at all times.

Never switch off the main power. When the main power is on, the automatic maintenance function is carried out periodically. If the automatic maintenance is not carried out, the printer may malfunction. For example, the print heads may be damaged.

Never switch off the main power or unplug the power cord suddenly while operation is in progress.

Switching off the main power or unplugging the power cord suddenly while operation is in progress may damage the print heads. Be sure to first switch off the sub power. If the main power is accidentally switched off, immediately turn the main and sub power back on.

POINT!

When not using the machine, remove any media and store it in a suitable environment.

If the machine is left with the media loaded, the media may be damaged, which may adversely affect printing. When not using the machine, remove any media and store it in a suitable environment.

➤ P. 19 "Media Storage Environment"

2

Basic
Operation

Chapter 3

Maintenance:

Keeping the Machine in Good Working Order

Ink Pouch Replacement.....	60
Out-of-ink Warnings	60
Ink Pouch Replacement.....	61
Maintenance That Should Be Performed Daily.....	63
Disposing of Discharged Fluid	63
Cleaning.....	65
Care and Maintenance of the Print Heads.....	66
When Normal Cleaning Is Not Effective.....	67
Medium Cleaning.....	67
Powerful Cleaning.....	68
If Colors Are Uneven.....	69
Mixing the Ink by Shaking the Ink Pouch	69
Light Choke Cleaning.....	69
Maintenance That Should Be Performed More than Once a Month...71	
When Manual Cleaning Becomes Necessary	71
Manual Cleaning.....	72
Maintenance That Should Be Performed Every Six Months.....78	
Refreshing Subtanks (REFRESH SUBTANKS).....	78
When Problems Such as Dot Drop-Out Are Not Fixed	81
When Problems Such as Dot Drop-Out Are Not Fixed	81
Replacing Consumable Parts	83
Replacing the Wiper.....	83
Replacing the Felt Wiper.....	86
Replacing the Separating Knife.....	89
When Not in Use for a Prolonged Period.....	91
Keep Performing Maintenance.....	91
Alarm Feature	91
If the Machine has not been Used for Over One Month	91

Ink Pouch Replacement

Out-of-ink Warnings

☞ P. 61 "Ink Pouch Replacement"

If Using 4 Colors (CMYK)

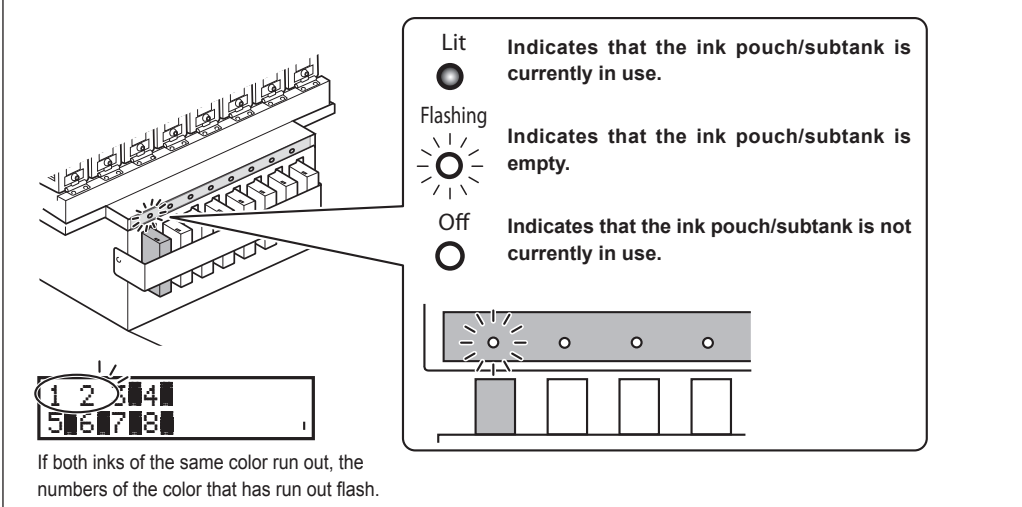

The diagram shows a top-down view of an ink cartridge assembly with four ink pouches. A legend defines the status of each pouch:

- Lit** (solid circle): Indicates that the ink pouch/subtank is currently in use.
- Flashing** (circle with radiating lines): Indicates that the ink pouch/subtank is empty.
- Off** (empty circle): Indicates that the ink pouch/subtank is not currently in use.

A secondary diagram shows a digital display with eight positions. The first four positions are labeled 1, 2, 3, and 4. The first two positions (1 and 2) are flashing, indicating that the corresponding ink colors have run out.

If both inks of the same color run out, the numbers of the color that has run out flash.

If one ink cartridge of the same color runs out, the machine continues printing using the other ink cartridge. When all ink cartridges of the same color run out, printing pauses and a warning beep sounds.

If Using 8 Colors (CMYKLcLmOrVi)

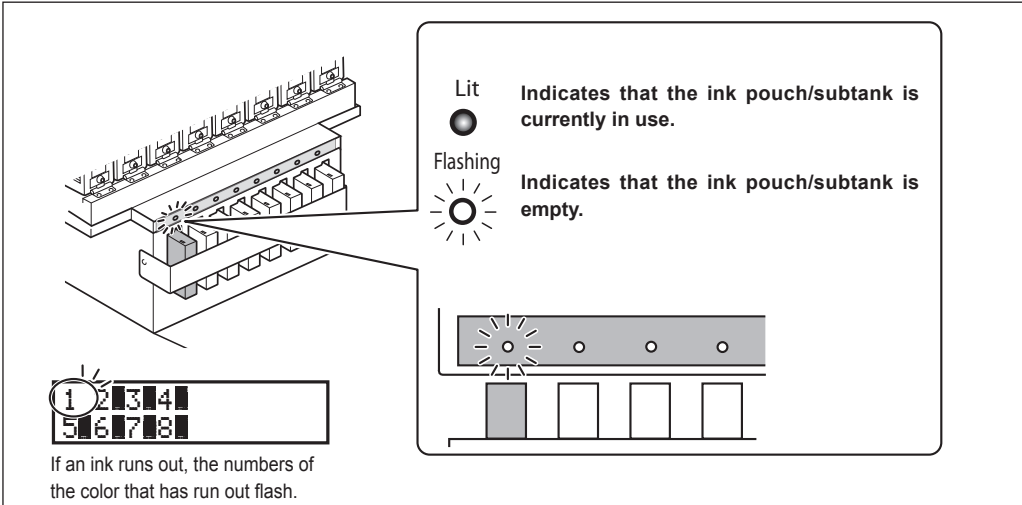

The diagram shows a top-down view of an ink cartridge assembly with eight ink pouches. A legend defines the status of each pouch:

- Lit** (solid circle): Indicates that the ink pouch/subtank is currently in use.
- Flashing** (circle with radiating lines): Indicates that the ink pouch/subtank is empty.

A secondary diagram shows a digital display with eight positions labeled 1 through 8. The first position (1) is flashing, indicating that the corresponding ink color has run out.

If an ink runs out, the numbers of the color that has run out flash.

When an ink runs out, printing pauses (unless the factory default settings have been changed,) and a warning beep sounds.

Ink Pouch Replacement

IMPORTANT! Precautions regarding ink pouch replacement

- Be sure to replace each pouch with an item of identical type and color.
- Install a pouch in each port. If there is a port that does not have a pouch installed, ink may dry up or air may enter the ink path, resulting in malfunction. Depending on the state of the machine, it may take some time to restore operation.
- Lower the ink pouch holders slowly without letting go. If you let go of the ink pouch holders partway through moving them, they will be subjected to a strong impact, which may cause the ink to leak.
- Never use an ink pouch that has already been used in another machine even if it is an identical type.
- Never mix different types of items.
- Never insert or remove a partially used ink pouch. Ink may leak.
- Do not remove subtanks.
- Take care not to drop ink pouches.

⚠ WARNING

Never store ink or discharged fluid in any of the following locations:

- Any location where high temperature may occur
- Near bleach or any other such oxidizing agent or explosive material
- Any location within the reach of children

Procedure

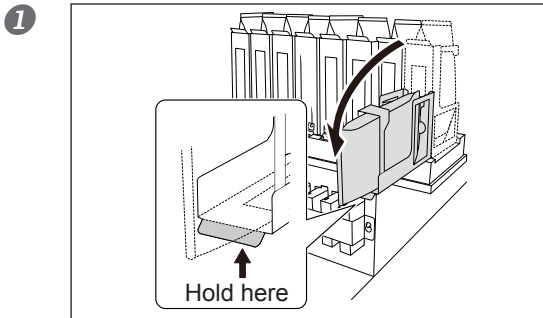

Pull the ink pouch holder for the empty ink forward.

Lower the ink pouch holders slowly without letting go of them.

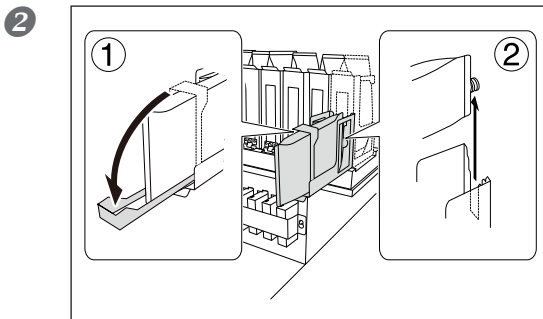

① **Remove the stoppers.**

② **Remove the ink pouch.**

If ink gets on the machine or the floor when removing an ink pouch, wipe it off with a dry cloth or similar object.

IMPORTANT!

Do not raise an ink pouch holder if there is no ink pouch installed in it. Doing so may cause air to enter the ink path, resulting in malfunction. It may take some time to restore operation in the event of malfunction.

3

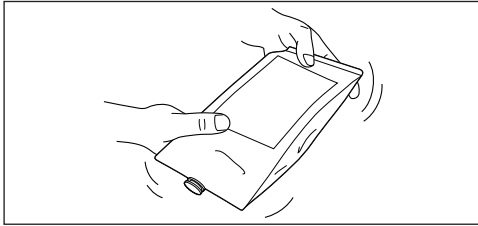

Shake an ink pouch of the same type and color 50 times (for around 15 seconds).

If ink components precipitate, it will not be possible to print with correct colors.

4

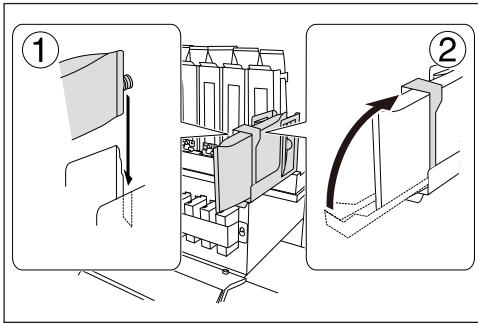

① Install the new ink pouch.

Install the new ink pouch, taking care to use the right color.

② Attach the stoppers.

Take care not to crush the ink pouches.

5

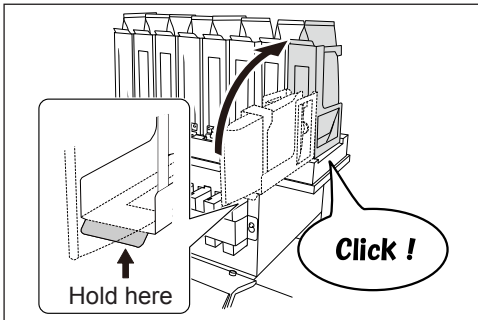

Raise the ink pouch holder.

Raise the ink pouch holders slowly without letting go of them.

IMPORTANT!

When installing an ink pouch and returning the ink pouch holder to its original position, raise the ink holder firmly until it clicks into place. Ink will leak if the ink pouch holder is not returned to the correct position.

Maintenance That Should Be Performed Daily

Disposing of Discharged Fluid

CHECK
DRAIN BOTTLE ↵

The drain bottle collects discharged fluid. Dispose of collected material before the bottle becomes full. The message shown in the figure appears when a certain amount of discharged fluid has collected in the bottle. Follow the procedure below to discard the discharged fluid.

Procedure

1 CHECK
DRAIN BOTTLE ↵

When the message shown in the figure appears, press **ENTER**.

2 Press **MENU**.

3 MENU
SUB MENU

Press **▼** several times until the screen on the left appears.

Press **▶**.

4 SUB MENU
MAINTENANCE

Press **▼** several times until the screen on the left appears.

Press **▶**.

5 MAINTENANCE
DRAIN BOTTLE ↵

Press **▼** several times until the screen on the left appears.

Press **ENTER**.

6 EMPTY
DRAIN BOTTLE ↵

When the screen shown on the left is displayed, remove the bottle and discard the discharged fluid.

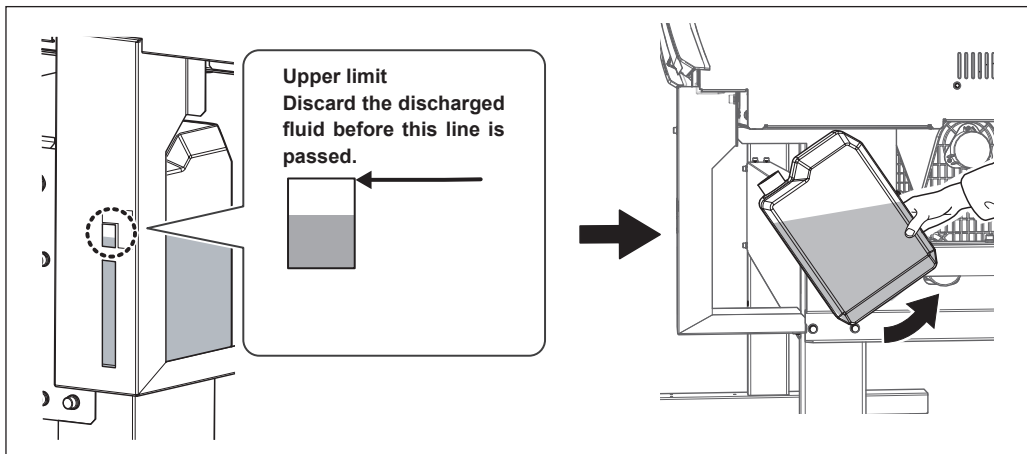

⚠ CAUTION

Before you detach the drain bottle, be sure to wait for the screen to display **"EMPTY DRAIN BOTTLE."**

Failing to follow this procedure may cause discharged fluid to flow out of the tube and spill onto your hands or the floor and cause a stain.

7 EMPTY
DRAIN BOTTLE ↵

Attach the emptied drain bottle to the machine once more. Press **ENTER**.

8  Press .

9 Press , then  to go back to the original screen.

⚠WARNING Never place discharged fluid or ink near an open flame. Doing so may cause a fire.

⚠CAUTION To store discharged fluid temporarily, place it in the included drain bottle or in a durable sealed container such as a metal can or polyethylene tank, and cap the container tightly. Any spillage or vapor leakage may cause a fire, an odor, or physical distress.

Dispose of discharged fluid properly, in accordance with the laws in effect in your locale.

Discharged fluid is flammable and contains toxic ingredients. Never attempt to incinerate discharged fluid or discard it with ordinary trash. Also, do not dispose of fluid in sewer systems, rivers, or streams. Doing so may have an adverse impact on the environment.

If It Is Not Possible to Check the Amount of Discharged Fluid in the Drain Bottle

Sometimes, ink affixes to the inside of the drain bottle, which makes it difficult to check the amount of discharged fluid. In this situation, clean the inside of the drain bottle.

Cleaning method A

Scrape the inside of the drain bottle clean using one of the included cleaning sticks.
Dispose of used cleaning sticks. They cannot be used for any other cleaning.
If this method is not effective, perform cleaning method B, shown below.

Cleaning method B (when cleaning method A is not effective)

- 1 Remove the drain bottle, which you will clean, from the machine.
- 2 Attach another drain bottle (included) to the machine.
- 3 When discarding the liquid from the removed drain bottle, leave about 2 to 3 cm (0.8 to 1.2 inches) of discharged fluid in the bottom of the bottle.
- 4 Securely cap the drain bottle.
- 5 Gently shake the drain bottle to wet the inside of the bottle with the discharged fluid. Tilt the drain bottle to make the entirety of the inside of the bottle wet.
- 6 Stand the bottle upright and leave it for 1 to 2 hours.
- 7 If ink stains are not cleaned sufficiently from the inside of the bottle, repeat steps 4 and 5.
- 8 Discard the remaining discharged fluid.

Cleaning

⚠️ WARNING

Never use gasoline, alcohol, thinner, or any other flammable material. Doing so may cause a fire.

⚠️ CAUTION

Before attempting cleaning, switch off the sub power and wait until the platen and dryer cool (approximately 30 minutes). Sudden movement of the machine may cause injury, or hot components may cause burns.

Wipe away any ink or grime on the media path and other areas as part of the daily cleaning procedure. Pinch rollers, grit rollers, and the platen are particularly prone to the buildup of grime. Clean by wiping with a cloth moistened with neutral detergent diluted with water then wrung dry.

POINT!

- This machine is a precision device and is sensitive to dust and dirt. Perform cleaning on a daily basis.
- Never attempt to oil or lubricate the machine.

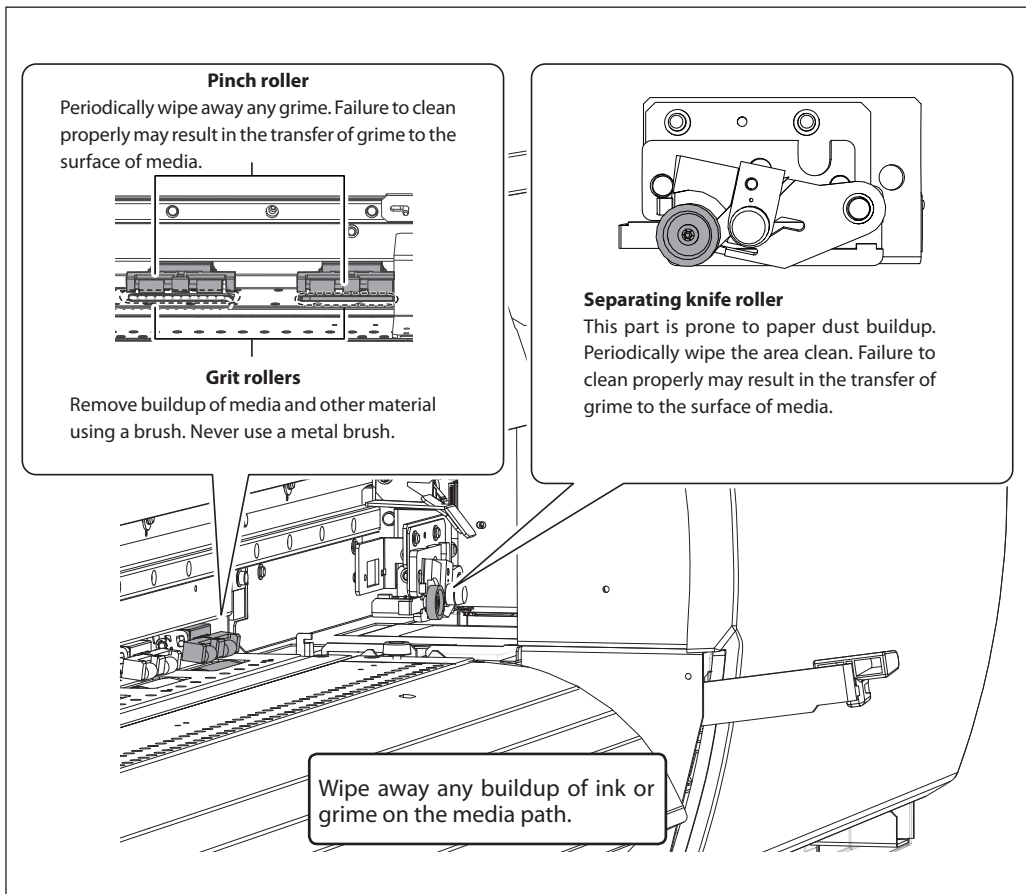

Care and Maintenance of the Print Heads

To keep a stable printing condition at all times, the print heads need to be maintained. There are maintenance tasks that should be performed daily and those that should be performed periodically.

Daily Care and Maintenance

➤ **Printing tests and normal cleaning**

We recommend performing a printing test and normal cleaning before day-to-day operation.

☞ P. 49 "Printing Tests and Normal Cleaning"

Periodic Care and Maintenance

➤ **Medium cleaning/powerful cleaning**

Perform medium cleaning or powerful cleaning when problems such as dot drop-out are not corrected after performing normal cleaning.

☞ P. 67 "Medium Cleaning"

➤ **Manual cleaning**

Perform manual cleaning periodically according to the frequency of use.

☞ P. 72 "Manual Cleaning"

➤ **Refreshing sub tanks (REFRESH SUBTANKS)**

Perform this procedure once every six months. (This procedure is effective when light choke cleaning does not resolve uneven color issues.)

☞ P. 78 "Refreshing Sub tanks (REFRESH SUBTANKS)"

Care and Maintenance When Uneven Color Occurs

➤ **Light choke cleaning**

Perform this procedure when printed colors are unstable or uneven, e.g., when color density is inconsistent even if the same data is printed with the same settings.

☞ P. 69 "Light Choke Cleaning"

➤ **Refreshing sub tanks (REFRESH SUBTANKS)**

Use this procedure when light choke cleaning does not resolve uneven color issues. (Note that it is necessary to perform this procedure once every six months regardless of whether or not there are problems with uneven colors.)

☞ P. 78 "Refreshing Sub tanks (REFRESH SUBTANKS)"

* The print heads are components that wear out. Periodic replacement is required, with the frequency of replacement depending on use. Purchase them from your authorized Roland DG Corp. dealer.

When Normal Cleaning Is Not Effective

POINT!

Medium and powerful cleaning consume more ink than normal cleaning, and overly frequent use may damage the print heads themselves. Avoid performing more than necessary.

Medium Cleaning

When problems such as dot drop-out are not resolved by normal cleaning (P. 49 "Printing Tests and Normal Cleaning"), perform the more forceful "medium cleaning" to remove clogging from the print heads.

Procedure

1 Perform a printing test.

☞ P. 49 "Printing Tests and Normal Cleaning"

When the printing test is complete, remove the media.

2 Press **CLEANING**.

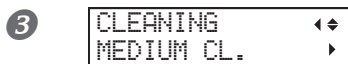



Press  to display the screen shown on the left.
Press .

4 Check for the group with dot drop-out by viewing the printing-test results.

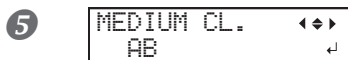
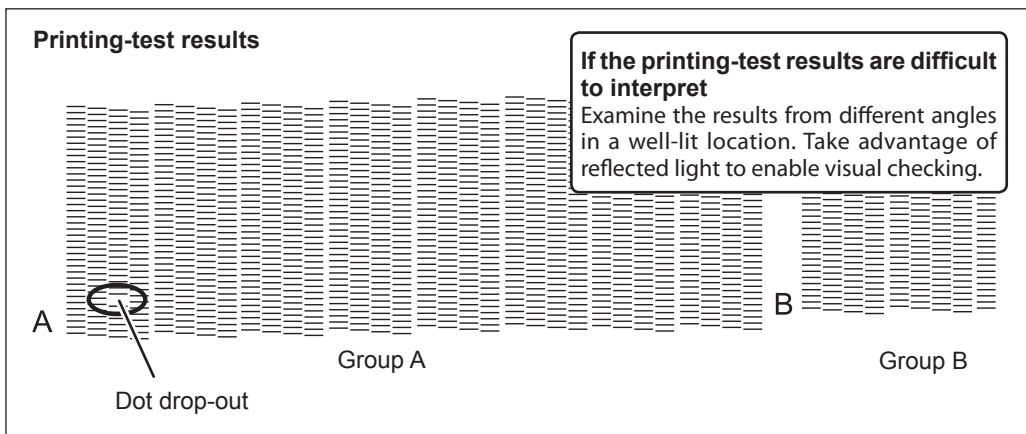
With medium cleaning, only the group of print heads having dot drop-out is cleaned.



Press  or  to select the group of print heads that is not to be cleaned.

Press  or  to get rid of the group display.
Repeat this process to display only the group of print heads that requires cleaning.

The only groups that can be cleaned are those that are displayed as A or B.

- 6 Press **ENTER**.

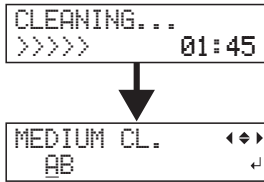

The screen shown in the figure appears, and then cleaning starts. The (approximate) remaining time for the procedure is displayed on the screen. ("01:45" = "1 minute and 45 seconds")

When cleaning finishes, the screen shown in the figure appears again.

- 7 Press **MENU**, then **←** to go back to the original screen.

If problems such as dot drop-out persist even after you have performed medium cleaning, perform the more powerful "powerful cleaning."

Powerful Cleaning

Procedure

- 1 Press **CLEANING**.



Press **▲** to display the screen shown on the left.
Press **ENTER**.

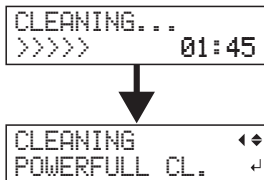

The screen shown in the figure appears, and then cleaning starts. The (approximate) remaining time for the procedure is displayed on the screen. ("01:45" = "1 minute and 45 seconds")

When cleaning finishes, the screen shown in the figure appears again.

- 3 Press **MENU**, then **←** to go back to the original screen.

When powerful cleaning is not effective

If problems such as dot drop-out persist even after you have performed powerful cleaning several times, perform manual cleaning. Such cleaning can be effective when carried out periodically, according to the frequency of use.

☞ P. 72 "Manual Cleaning"

If Colors Are Uneven

Mixing the Ink by Shaking the Ink Pouch

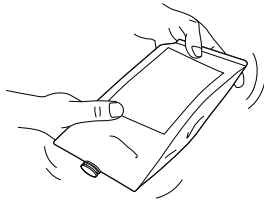

If ink components precipitate in the ink pouch, colors may be uneven (unevenness in printed colors). If colors are uneven, remove the ink pouches and shake them gently.

IMPORTANT!

- **Before shaking an ink pouch, wipe off any ink from around the mouth of the ink pouch.**
If you do not wipe off the ink, it may splatter when you shake the ink pouch.
- **When you have finished agitating the ink, reattach the ink pouch immediately.**
Taking time to reattach the pouch will adversely affect the ink path.
- **When installing an ink pouch and returning the ink pouch holder to its original position, raise the ink holder firmly until it clicks into place.**
Ink will leak if the ink pouch holder is not returned to the correct position.

If uneven color issues are not resolved even after shaking the ink pouches, perform light choke cleaning.

Light Choke Cleaning

IMPORTANT!

Light choke cleaning consumes a lot of ink, and overly frequent use may damage the print heads themselves. Avoid performing more than necessary.

If printing is not performed for several days, printed colors may become unstable or uneven, e.g., when color density is inconsistent, even if the same data is printed with the same settings. In such cases, perform light choke cleaning. This will stabilize printed colors by agitating the ink.

Procedure

1 Press **MENU**.

2

MENU	◀▶
SUB MENU	▶

Press **▼** several times to display the screen shown on the left.

Press **▶**.

3

SUB MENU	◀▶
INK CONTROL	▶

Press **▲** several times to display the screen shown on the left.

Press **▶**.

4

```

IN K CONTROL
L I G H T C H O K E C L .
    
```

Press  several times to display the screen shown on the left.
Press .

If the message [EMPTY DRAIN BOTTLE] is displayed on the screen

```

E M P T Y
D R A I N B O T T L E
    
```

When the screen shown on the left is displayed, discard the discharged fluid. When you attach the empty drain bottle to the machine again and press , the machine performs the procedure below.

 **CAUTION**

The discharged fluid must be discarded at this stage.

If you do not discard it at this stage, discharged fluid will overflow from the drain bottle during the procedure that follows.

 **CAUTION**

Before you detach the drain bottle, be sure to wait for the screen to display [EMPTY DRAIN BOTTLE].

Failing to follow this procedure may cause discharged fluid to flow out of the machine and spill, soiling your hands or the floor.

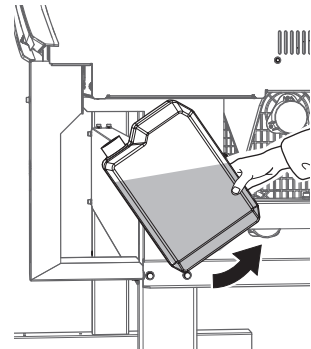

```

C L E A N I N G . . .
>>
    
```

The screen on the left is displayed.
The (approximate) remaining time for the procedure is displayed on the screen. ("01:45" = "1 minute and 45 seconds")

```

IN K CONTROL
L I G H T C H O K E C L .
    
```

When finished, the screen shown on the left appears again.

5

Press , then  to go back to the original screen.

If uneven color issues are not resolved by light choke cleaning, refresh the sub tanks.

➤ P. 78 "Refreshing Subtanks (REFRESH SUBTANKS)"

Maintenance That Should Be Performed More than Once a Month

When Manual Cleaning Becomes Necessary

Perform Manual Cleaning Once a Month or More

To keep the stable printing condition at all times, perform manual cleaning once a month or more. Manual cleaning takes approximately 10 minutes.

Manual Cleaning Is Recommended When The Following Symptoms Occur

It is recommended to perform manual cleaning when any of the symptoms given below occur and cannot be solved by automatic cleaning functions such as normal cleaning.

Replacing the wiper or felt wiper is also an effective means of improving the symptoms.

☞ P. 83 "Replacing the Wiper", P. 86 "Replacing the Felt Wiper"

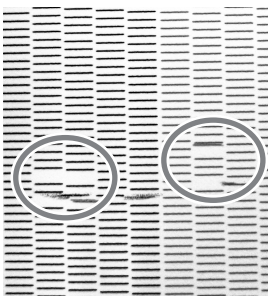
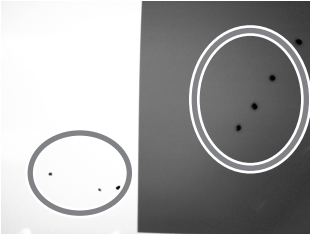
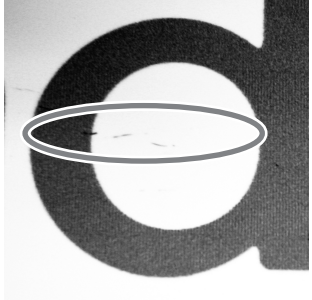
Dot drop-out/Dot displacement	Ink drips	Dragging dirt
		
Dust or other foreign matter adheres to the print heads and impedes correct ink discharge.	Ink accumulates on dirty areas around the print heads and drips onto the media.	Dirt accumulates on the area around the print heads and touches the media.

- If you use up the cleaning sticks used for manual cleaning, contact your authorized Roland DG Corp. dealer.
- The print heads are components that wear out. Periodic replacement is required, with the frequency of replacement depending on use. Contact your authorized Roland DG Corp. dealer.

Manual Cleaning

IMPORTANT!

Important notes on this procedure

- Before attempting this operation, remove any media.
- To prevent the print heads from drying out, finish this procedure in 30 minutes or less. A warning beep sounds after 30 minutes.
- Never use any implements other than the included cleaning sticks. Cotton swabs or other lint-producing items may damage the print heads. If you use up the cleaning sticks, contact your authorized Roland DG Corp. dealer.
- Use one cleaning stick per cleaning session, and then discard the stick after use. Reusing cleaning sticks will adversely affect the printing results.
- Never rub the print head surface (nozzle surface).
- Stroke the sponges very gently, applying as little pressure as possible. Never rub, scrape, or crush them.

If a warning beep sounds during cleaning

A warning beep sounds 30 minutes after operation starts. Temporarily stop work, attach the left and right covers, and then close the front cover. Press **ENTER** to finish manual cleaning mode. After that, restart operation from the first procedure.

⚠ CAUTION

Be sure to perform operations as specified in the instructions, and never touch any area not specified in the instructions.

Failure to observe these instructions may cause the machine to move suddenly, resulting in injury.

Required items



Cleaning sticks

1. Enter manual cleaning mode.

1 Remove any media.

2 Press **MENU**.

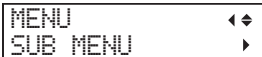
3 

Press **▼** several times until the screen on the left appears.

Press **▶**.



Press several times until the screen on the left appears.

Press .



Press .



When the screen shown on the left is displayed, open the right cover.

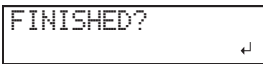
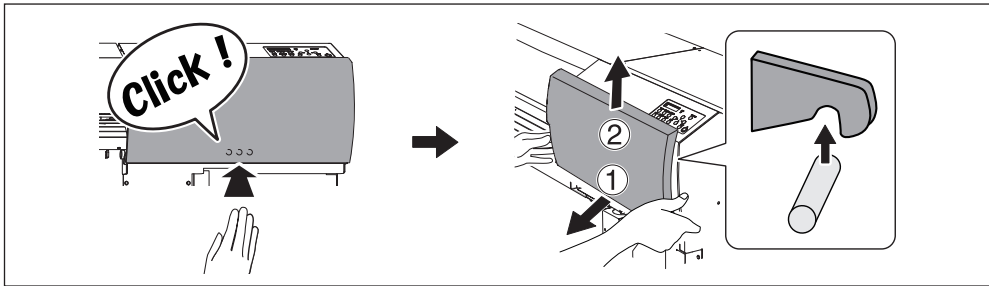

Preparations are complete when this screen appears.

2. Clean the wipers using a cleaning stick.

Note: Clean the two wipers one at a time.

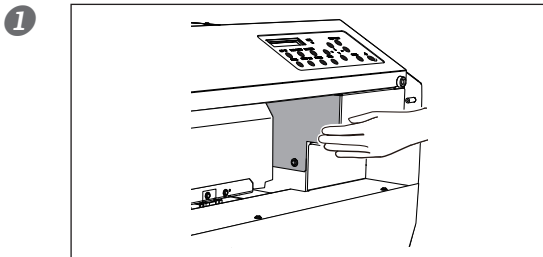

Touch the location shown in the figure to discharge any static electricity.

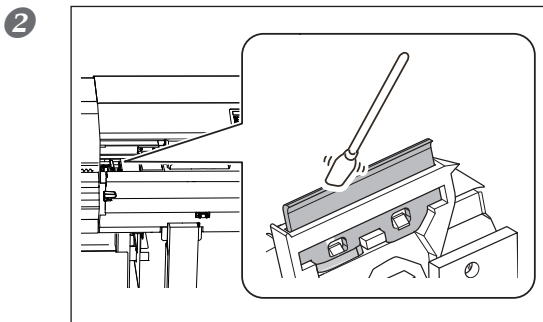

Clean the first wiper.

3 When cleaning is finished, press .

- 4 CLOSE COVER R Close the right cover.

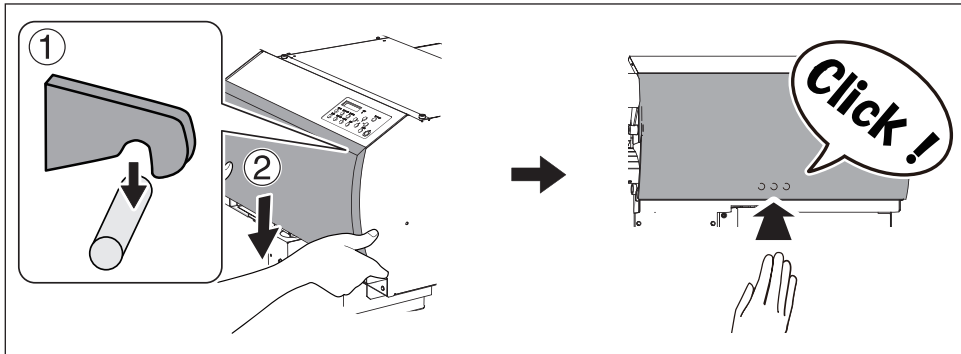

- 5 OPEN COVER R When the screen shown on the left is displayed, open the right cover.

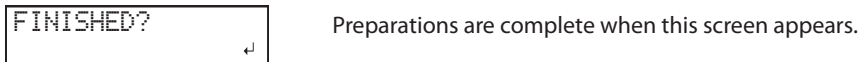

- 6 Clean the second wiper.

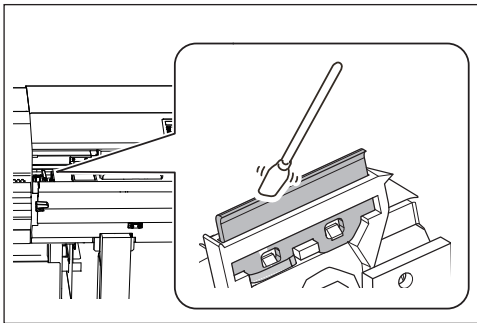

- 7 When cleaning is finished, press ENTER.

- 8 CLOSE COVER R Close the right cover.



3. Clean the area around the print heads with the cleaning stick.

1

OPEN COVER L

Open the left cover.

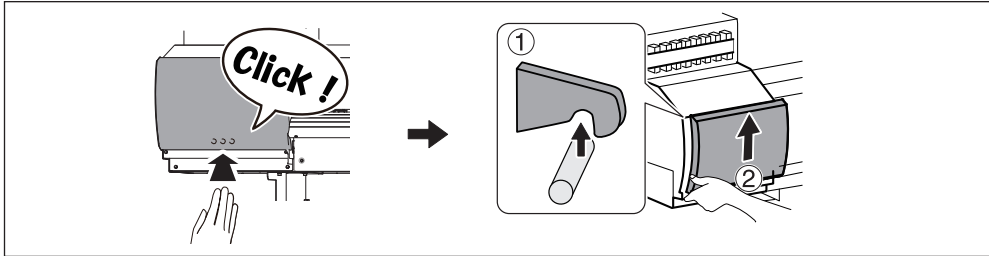

REMOVE CUT
RAIL ↵

Remove the bolt (1), and then remove the cut rail (2).
Press **ENTER**.

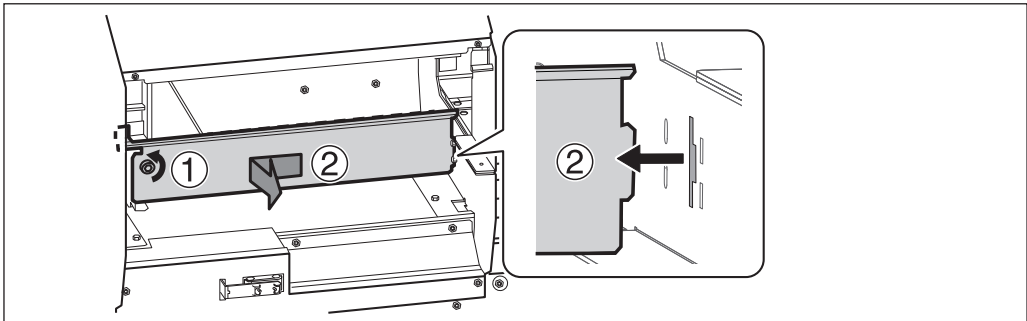

2

CLOSE COVER L

Close the left cover.

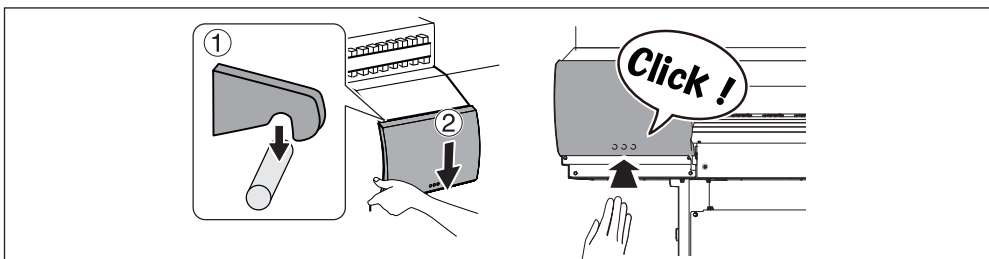

3

OPEN COVER L

Open the left cover.

4

OPEN COVER R

Open the right cover.

FINISHED? ↵

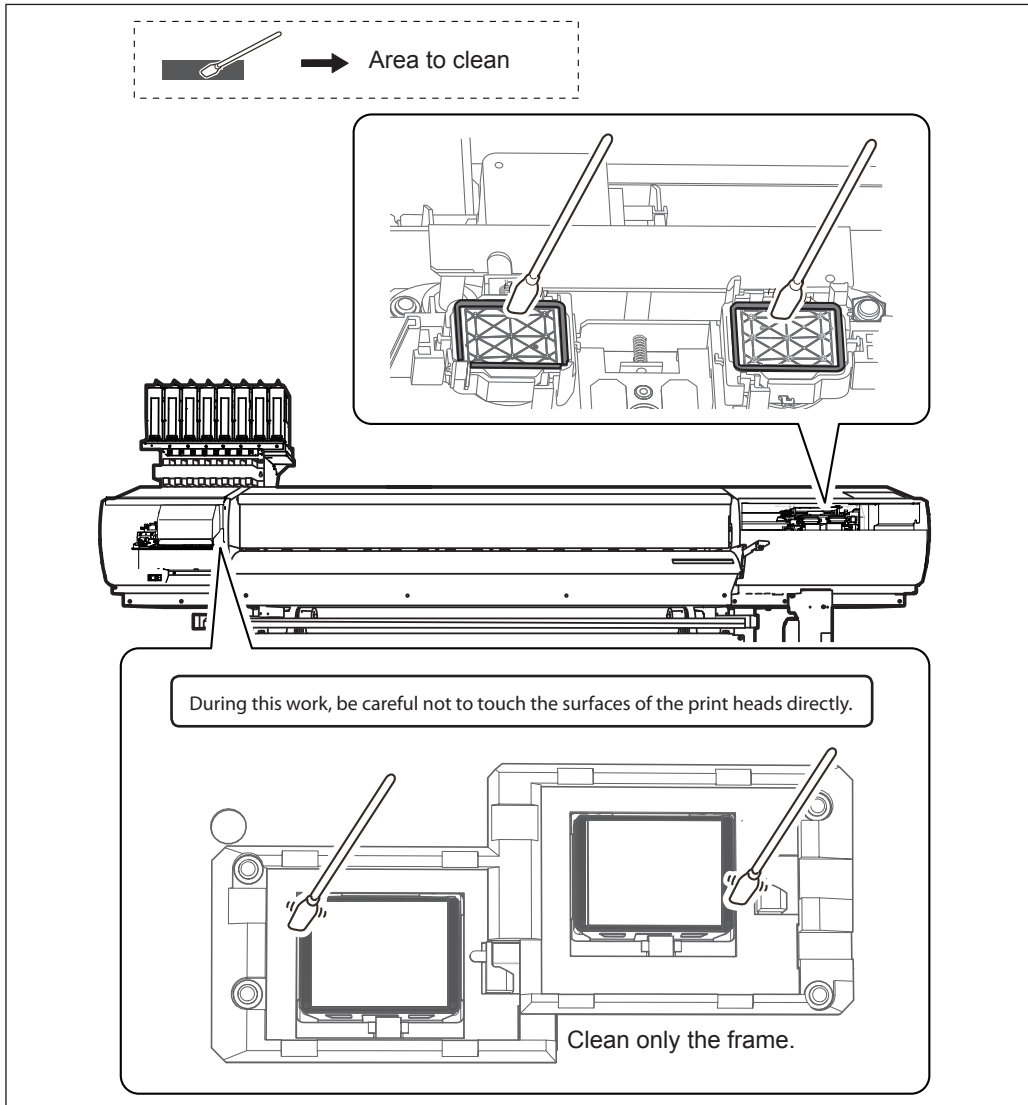

Preparations are complete when this screen appears.

- 5 Clean the locations shown in the following figure.
Be especially careful to clean away any fibrous dust (lint).



- 6 When cleaning is finished, press **ENTER**.

4. Reattach the left and right covers, and finish manual cleaning mode.

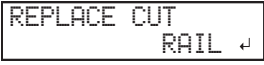
- 1  Close the left cover.
- 2  Close the right cover.
- 3  Open the left cover.
- 4  Attach the cut rail (①), and then tighten the bolt (②). Press **ENTER**.

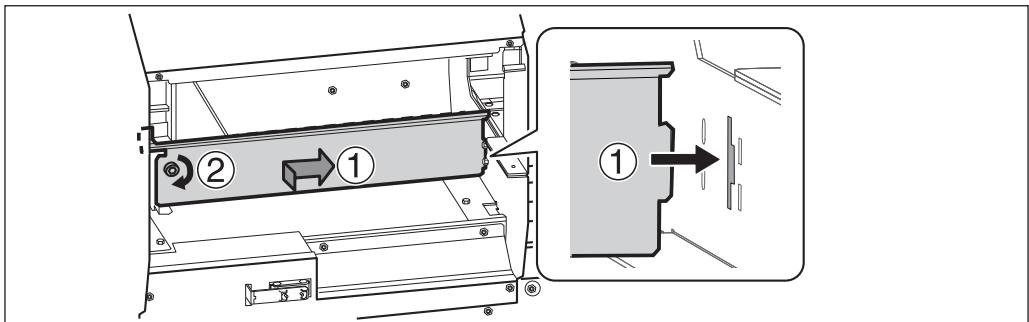

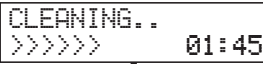
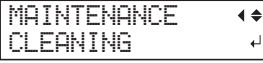
- 5  Close the left cover.
- 
- The screen shown in the figure appears, and then cleaning starts. The (approximate) remaining time for the procedure is displayed on the screen. ("01:45" = "1 minute and 45 seconds")
- 
- When cleaning finishes, the screen shown in the figure appears again.

- 6 Press **MENU**, then **←** to go back to the original screen.

5. Perform a printing test to verify the results of the procedure.

Perform a printing test to check the results.

Perform cleaning using the machine's cleaning feature several times when necessary.

☞ P. 49 "Printing Tests and Normal Cleaning"

Maintenance That Should Be Performed Every Six Months

Refreshing Subtanks (REFRESH SUBTANKS)

Refresh the subtanks once every six months to resolve issues with ink components precipitating in the subtanks. If this procedure is not performed once every six months, print quality may be adversely affected, e.g., printed colors may be uneven.

This operation is effective when light choke cleaning does not resolve uneven color issues.

IMPORTANT!

Refreshing the subtanks consumes more ink and places more of a strain on the print heads than light choke cleaning. Undertake this procedure with caution if performing it more than once every six months.

1. Enter the [REFRESH SUBTANK] menu.

1 Press **MENU**.



2 

Press  several times to display the screen shown on the left.

Press .

3 

Press  several times to display the screen shown on the left.

Press , then .

4 

Press **ENTER**.

2. Start refreshing the subtanks.

1 

When the screen on the left is displayed, remove the drain bottle and discard the discharged fluid.

⚠ CAUTION

When [EMPTY DRAIN BOTTLE] is displayed, you must discard the discharged fluid. If you do not discard it at this stage, discharged fluid will overflow from the drain bottle during the procedure that follows.

⚠ CAUTION

Before you detach the drain bottle, be sure to wait for the screen to display [EMPTY DRAIN BOTTLE].

Failing to follow this procedure may cause discharged fluid to flow out of the machine and spill, soiling your hands or the floor.

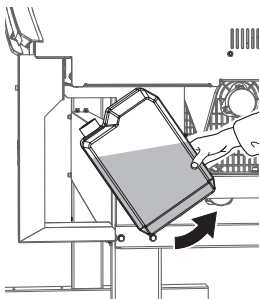

2 After discarding the discharged fluid, press **ENTER**.

IMPORTANT! Precautions for the operations to follow

- Take care not to drop ink pouches.
- During this work, move the ink pouch holders slowly. If you let go of the ink pouch holders partway through moving them, they will be subjected to a strong impact, which may cause the ink to leak.

3 DOWN INK POUCH HOLDER ↵

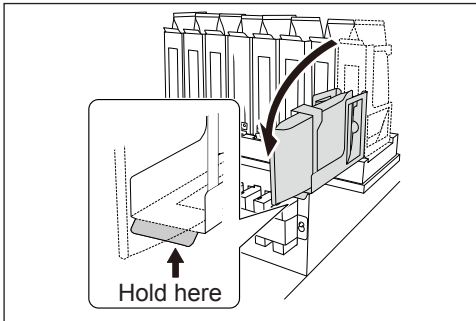

Pull all the ink pouch holders forward.

Lower the ink pouch holders slowly without letting go of them.

4 Press **ENTER**.

5 REMOVE INK POUCH
12345678 ↵

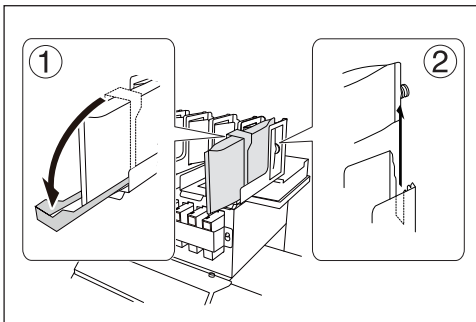

① Remove the stoppers.

② Remove all the ink pouches.

If ink gets on the machine or the floor when removing an ink pouch, wipe it off with a dry cloth or a similar object.

6 Press **ENTER**.

7 EMPTY
DRAIN BOTTLE ↵

When the screen on the left is displayed, remove the drain bottle and discard the discharged fluid.

8 Press **ENTER**.

"EMPTY DRAIN BOTTLE" appears on the screen several times. Repeat steps 7 and 8.

3. Finish refreshing the subtanks.

1 SET INK POUCH
12345678

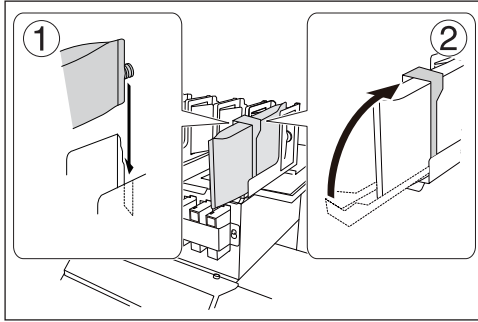

① **Install all the ink pouches.**

Take care to use the right colors.

② **Attach the stoppers.**

Take care not to crush the ink pouches.

2 Press **ENTER**.

3 UP INK POUCH
12345678

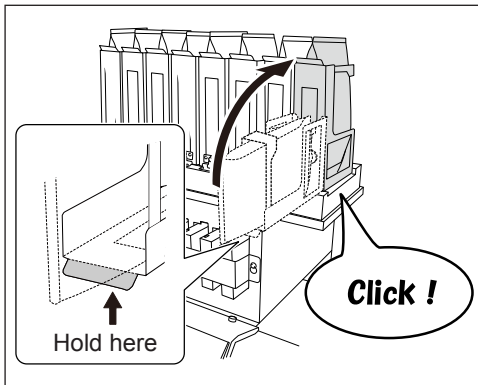

Raise all the ink pouch holders.

Raise the ink pouch holders slowly without letting go of them.

IMPORTANT!

When installing an ink pouch and returning the ink pouch holder to its original position, raise the ink holder firmly until it clicks into place. Ink will leak if the ink pouch holder is not returned to the correct position.

4 Press **ENTER**.

5 EMPTY
DRAIN BOTTLE

When the screen on the left is displayed, remove the drain bottle and discard the discharged fluid.

6 Press **ENTER**.

INK CONTROL
REFRESH SUBTANK

When finished, the screen shown on the left appears again.

7 Press **MENU** to go back to the original screen.

When Problems Such as Dot Drop-Out Are Not Fixed

When Problems Such as Dot Drop-Out Are Not Fixed

Perform the procedure below if ink discharge issues such as dot drop-out are not corrected after performing cleaning using the cleaning function (normal, medium, powerful) or manual cleaning.

IMPORTANT!

A large amount of ink will be discharged during this operation. Perform this operation only when dot drop-out cannot be corrected even after performing cleaning using the cleaning function (normal, medium, powerful) or manual cleaning.

☞ P. 63 "Maintenance That Should Be Performed Daily", P. 67 "When Normal Cleaning Is Not Effective", P. 71 "Maintenance That Should Be Performed More than Once a Month"

Procedure

1 Discard the discharged fluid in the drain bottle.

Refer to P. 63 "Disposing of Discharged Fluid" to discard the discharged fluid. Start from step 2.

CAUTION

The discharged fluid must be discarded at this stage.

A large amount of ink will be discharged during this operation. The discharged fluid must be discarded at this stage. If you do not discard it at this stage, discharged fluid may overflow from the drain bottle during the procedure that follows.

2 Press **MENU**.



Press **▼** several times to display the screen shown on the left.

Press **▶**.



Press **▼** several times until the screen on the left appears.

Press **▶**.

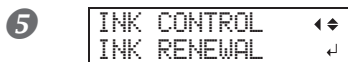

Press **▼** several times until the screen on the left appears.

Press **ENTER**.

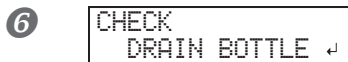

Check that the drain bottle is empty, and then press

ENTER.

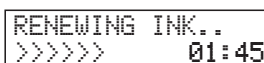

The screen shown in the figure appears.

The (approximate) remaining time for the procedure is displayed on the screen. ("01:45" = "1 minute and 45 seconds")



When cleaning finishes, the screen shown in the figure appears again.

7 Press **MENU**, then **◀** to go back to the original screen.

POINT!

Cleaning the print head surface as an emergency measure

When dot drop-out or dot deflection is not improved even if cleaning is performed several times, you can clean the surface of the print heads as an emergency measure. The print head surface (nozzle surface) is a very delicate mechanism, so work must be performed carefully and cautiously.

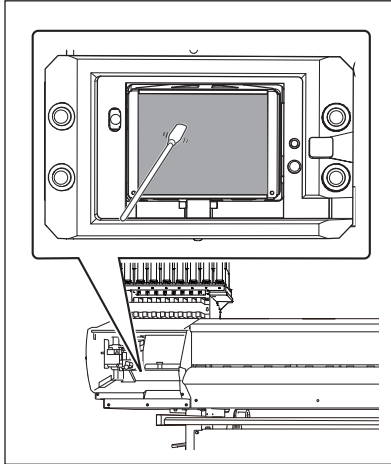

Very gently touch the cleaning stick against the print head surface (nozzle surface).

Very softly press the cleaning stick against the print head surface. Never rub the stick or press it forcefully against the print head surface.

This procedure is an emergency measure. Depending on symptoms, it may damage normal areas and cause symptoms to worsen. If you have any questions, contact your authorized Roland DG Corp. dealer.

Replacing Consumable Parts

Replacing the Wiper

The wiper is a component that is used for cleaning the print heads. When the screen displays a message like the one shown below, it is time to replace the items. There are two wipers. Replace both wipers with new ones.

TIME FOR
WIPER REPLACE ↵

For information about purchasing wipers, contact your authorized Roland DG Corp. dealer.

⚠ CAUTION

Be sure to perform operations as specified by the instructions, and never touch any area not specified in the instructions.

Failure to observe these instructions may cause the machine to move suddenly, resulting in injury.

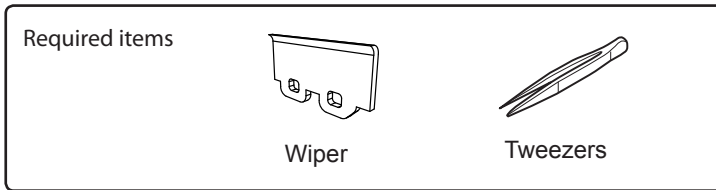

1. Enter the wiper replacement menu.

① 

When the screen on the left is displayed, press .

② Remove any media.

③ Press .

④ 

Press  several times to display the screen shown on the left.

Press .

⑤ 

Press  several times to display the screen shown on the left.

Press .

⑥ 

Press  several times to display the screen shown on the left.

Press .

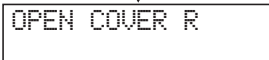
The print-head carriage moves to a location where wiper replacement is possible, and then the screen shown on the left appears.

2. Replace the wiper.

1 Open the right cover.

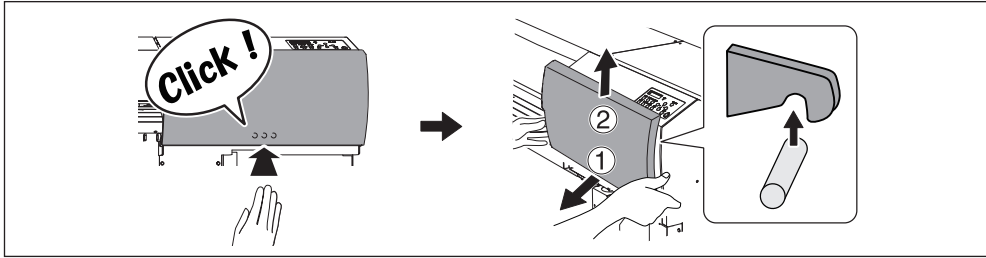

Preparations are complete when this screen appears.

2

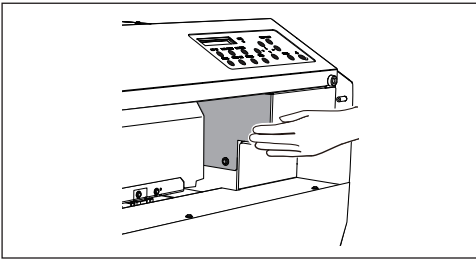

Touch the location shown in the figure to discharge any static electricity.

3 Replace the first wiper.

Removing an old wiper

Tweezers (included)

Hook

Detach the hook.
Using the tweezers to press on the hook in the hole on the wiper makes it easier to remove the wiper.

Pull up and out.

Point

If the area is dark and difficult to see, use a flashlight or a similar device to illuminate the area.

Attaching a new wiper

Place the inclined end on the back side.
If the wiper is installed with the incorrect orientation, appropriate cleaning will not be possible.

Attach the part to the hooks.
Be sure to attach the part to the hooks. Failure to do so may result in dot drop-out or other problems.

Hook

4 Press **ENTER** .

5 **CLOSE COVER R** Close the right cover.

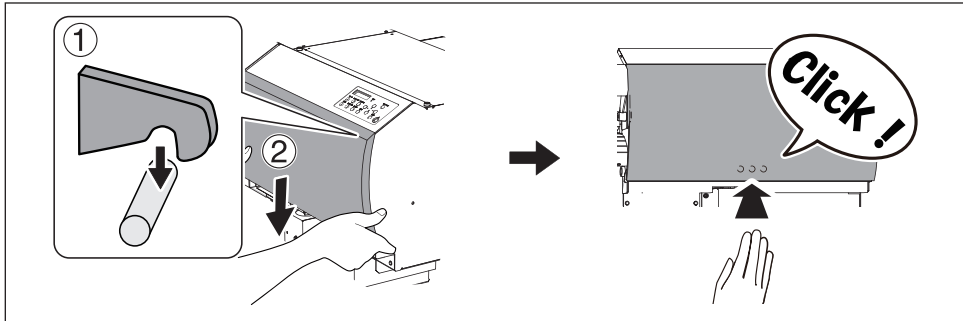

6 **OPEN COVER R** Open the right cover.

FINISHED? Preparations are complete when this screen appears.

7 **Replace the second wiper.**
The replacement procedure is the same as for the first wiper. Refer to the illustration shown in step 3.

3. Exit the wiper replacement menu.

1 Press **ENTER** .

2 **CLOSE COVER R** Close the right cover.

MAINTENANCE ◀
REPLACE WIPER ▶

After the process to exit the wiper replacement menu is performed, the screen shown in the figure appears.

3 Press **MENU** , then **◀** to go back to the original screen.

4. Perform a printing test to verify the results of the procedure.

Perform a printing test to check the results.

☞ P. 49 "Printing Tests and Normal Cleaning"

Replacing the Felt Wiper

The felt wiper is a component that is used for cleaning the print heads. When the screen displays a message like the one shown below, it is time to replace the items. There are two felt wipers. Replace both felt wipers with new ones.



For information about purchasing felt wipers, contact your authorized Roland DG Corp. dealer.

⚠ CAUTION

Be sure to perform operations as specified by the instructions, and never touch any area not specified in the instructions.

Failure to observe these instructions may cause the machine to move suddenly, resulting in injury.

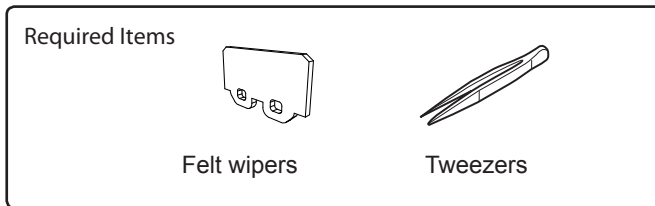

1. Enter the felt wiper replacement menu.



When the screen on the left is displayed, press **ENTER**.

2 Remove any media.

3 Press **MENU**.

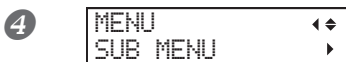

Press **▼** several times until the screen on the left appears.

Press **▶**.



Press **▼** several times until the screen on the left appears.

Press **▶**.



Press **▼** several times until the screen on the left appears.

Press **ENTER**.

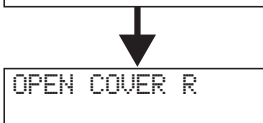

The print-head carriage moves to a location where felt wiper replacement is possible, and then the screen shown on the left appears.

2. Replace the felt wiper.

1 Open the right cover.

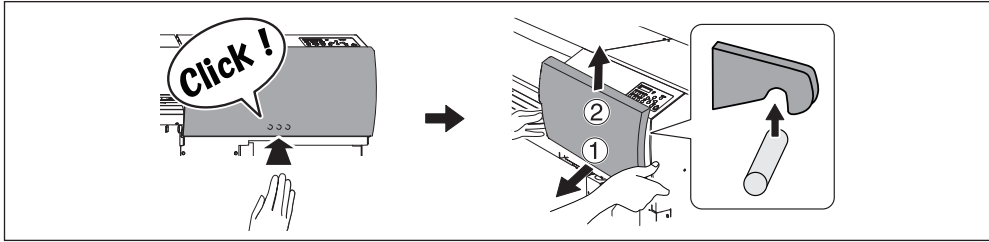

Preparations are complete when this screen appears.

2

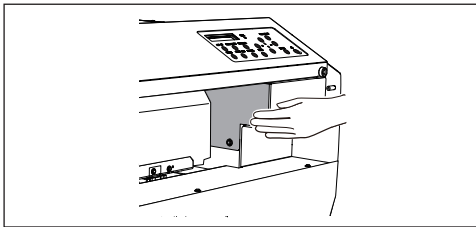

Touch the location shown in the figure to discharge any static electricity.

3 Open the front cover.

4 Replace the first felt wiper.

Removing an old felt wiper

Tweezers (included)

Hook

Detach the hook.
Using the tweezers to press on the hook in the hole on the felt wiper makes it easier to remove the felt wiper.

Pull up and out.

Point

If the area is dark and difficult to see, use a flashlight or a similar device to illuminate the area.

Attaching a new felt wiper

Attach the wiper to the hook.
Make sure the wiper catches on the hook. Failure to do so may result in dot drop-out or other problems.

Hook

5 Close the front cover.

6 Press **ENTER**.

7 **CLOSE COVER R** Close the right cover.

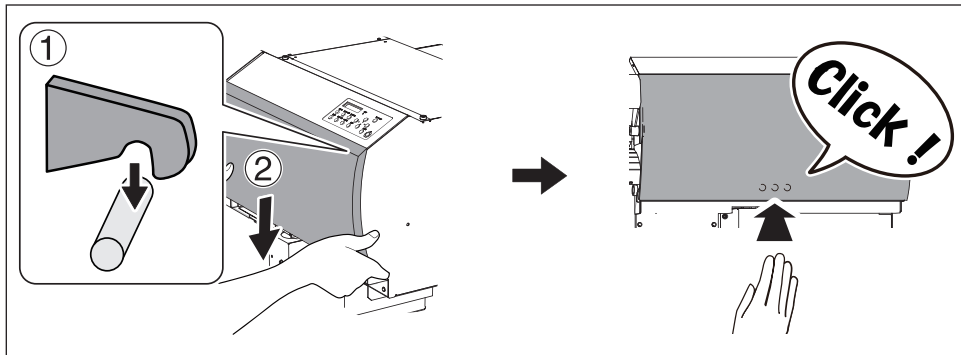

8 **OPEN COVER R** Open the right cover.

FINISHED? Preparations are complete when this screen appears.

9 Open the front cover.

10 Replace the second felt wiper.

The replacement procedure is the same as for the first felt wiper. Refer to the illustration shown in step 4.

3. Exit the felt wiper replacement menu.

1 Close the front cover.

2 Press **ENTER**.

3 **CLOSE COVER R** Close the right cover.

MAINTENANCE **REPLACE FELT** After the process to exit the felt wiper replacement menu is performed, the screen shown in the figure appears.

4 Press **MENU**, then **←** to go back to the original screen.

4. Perform a printing test to verify the results of the procedure.

Perform a printing test to check the results.

☞ P. 49 "Printing Tests and Normal Cleaning"

Replacing the Separating Knife

If the separating knife becomes dull, replace it with the included replacement knife.



CAUTION

Be sure to perform operations as specified by the instructions, and never touch any area not specified in the instructions.

Failure to observe these instructions may cause the machine to move suddenly, resulting in injury.



CAUTION

Do not touch the edge of the separating knife.

Doing so may result in injury.

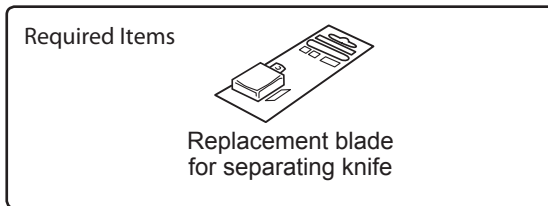

1. Enter the knife replacement menu.

1 Remove any media.

2 Press **MENU**.

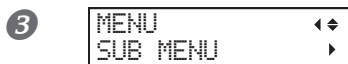

Press **▼** several times until the screen on the left appears.

Press **▶**.

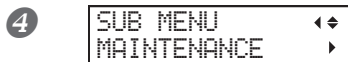

Press **▼** several times until the screen on the left appears.

Press **▶**.



Press **▼** several times until the screen on the left appears.

Press **ENTER**.

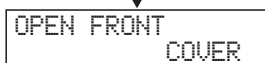
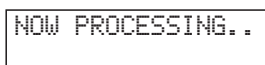

The print-head carriage moves to a location where knife replacement is possible, and then the screen shown on the left appears.

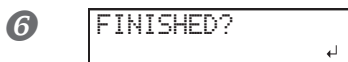

Open the front cover.

Preparations are complete when this screen appears.

2. Replace the separating knife.

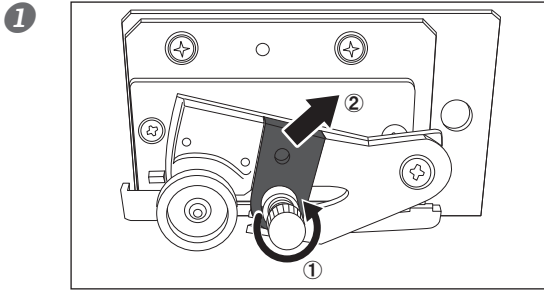

Remove the separating knife.

- ① Loosen the screw until it slips out.
- ② Grasp the screw portion, and slowly pull in the direction of the arrow. When doing this, do not pull it toward you.

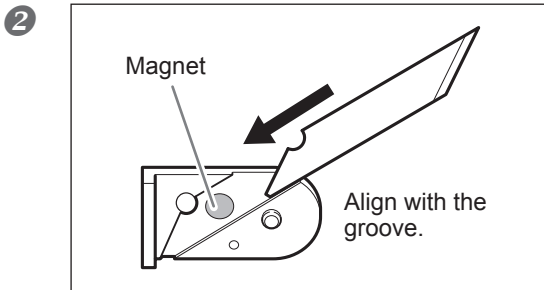

Install a new knife.

The knife is secured in place by the magnet.

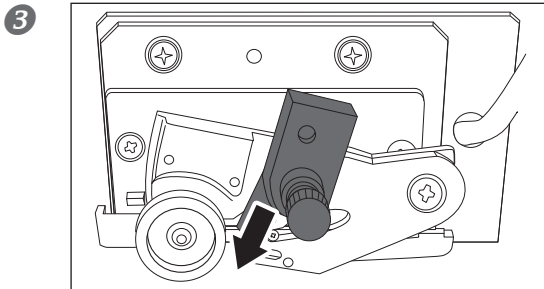

Slowly insert the knife into the groove.

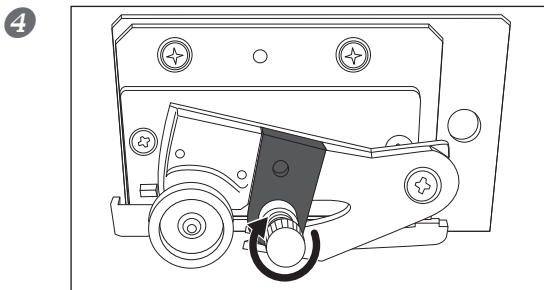

Tighten the screw.

Take care to ensure that the knife does not slip out of position at this time.

3. Exit the knife replacement menu.

- ① Close the front cover.
- ② Press **ENTER**.
- ③ Press **MENU** to go back to the original screen.

When Not in Use for a Prolonged Period

Keep Performing Maintenance

Switch on the power once a month

Switch on the sub power once a month. When you turn on the power, the machine automatically performs some operations such as those to keep the print heads from drying out. Leaving the machine unused for a prolonged period may damage the print heads, so be sure to switch on the power to perform these automatic operations.

Keep at a constant temperature and relative humidity

Even when the machine is not in use, keep it at a temperature of 15 to 30°C (59 to 86°F) and a relative humidity of 20 to 80% (with no condensation). Temperatures that are too high may degrade the ink and cause malfunctions. Temperatures that are too low may cause the ink to freeze and damage the print heads.

Alarm Feature



```
PRESS THE POWER  
KEY TO CLEAN
```

The alarm feature reminds you to switch on the sub power once a month. When the machine remains unused for about one month, this screen appears and a warning beep sounds. If this screen appears, switch on the sub power. When maintenance operations finish, switch off the sub power.

This feature operates when the machine's main power is turned on. Leave the main power switched on at all times even when the machine is to remain out of use for a prolonged period.

If the Machine has not been Used for Over One Month

If the machine has not been used for over one month, refresh the sub tanks. If you use the machine straight away without performing this procedure, printing may be adversely affected, e.g. printed colors may be unstable.

☞ P. 78 "Refreshing Subtanks (REFRESH SUBTANKS)"

Chapter 4

Advanced Functions

Fully Utilizing the Preset Function.....	94
Saving Various Settings as a Name Assigned Preset.....	94
Loading a Saved Preset.....	95
Automatic Loading of a Saved Preset When Media Is Loaded.....	96
Using the Dryer.....	97
What is the Dryer?.....	97
Setting the Temperature of the Dryer.....	98
Dryer Control While Idling.....	99
Drying the Trailing Edge of the Printing Area on the Dryer.....	100
Setting the Drying Time after Printing.....	101
Fully Utilizing the Correction Function.....	102
Correcting for Misalignment in Bidirectional Printing.....	102
Correcting for Misalignment in Bidirectional Printing More Precisely.....	102
Reducing Horizontal Bands (Feed Correction Function).....	103
Correcting Media Skew.....	104
Accommodating Different Media Types and Conditions.....	106
Adjusting Print Head Height to Match Media Thickness.....	106
Using Transparent Media.....	107
Using Hard-to-Dry Media.....	109
Using Media That Does Not Move Smoothly.....	109
Changing the Range of Print-head Carriage Movement.....	110
Expanding the Printing Area by Reducing the Margins.....	111
Preventing Soiling of the Media and Dot Drop-Out.....	112
Using Sticky Media.....	113
Printing with Crop Marks.....	114
Printing with Crop Marks.....	114
Using the Media Take-Up System.....	115
Using the Media Take-up System.....	115
Important Notice When Using the TUC-3.....	115

Fully Utilizing the Preset Function

Saving Various Settings as a Name Assigned Preset

Procedure

1 Press **MENU**.

2  MENU PRESET

Press **▼** to display the screen shown on the left.
Press **▶**, then **▼**.

3  PRESET SAVE

Press **▶**.

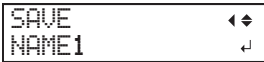
4  SAVE NAME1

Press **▲** or **▼** to select one option from NAME1 to NAME8.

Press **ENTER** to confirm your entry.

The current menu settings are saved.

5  SET NAME S

Press **▲** or **▼** to enter a character.

When you have selected the character you want to enter, press **▶**.

The characters you can enter are "A" through "Z," "0" through "9," and the "-" character. You can enter up to 15 characters, including spaces.

6  SET NAME SAMPLE

Press **▲** or **▼** to enter the next character.

Enter the following characters in the same way.

When you have finished, press **ENTER** to confirm your entry.

7 Press **MENU**, then **◀** to go back to the original screen.

Description

Using the [PRESET] menu lets you easily change a wide variety of settings to optimize them for the media. Up to eight types of presets can be saved. You can assign a name to each one. Using media names for these may aid recognition and clarity. Making changes for each menu item every time you change the media can be troublesome. That's why it can be useful to save the menu-item settings optimized for an often-used type of media as a preset. The next time you use the media, you can change the menu-item settings to the optimal values for the media simply by loading the preset you saved. The menu items that can be saved in presets are listed below.

[DRYER]	☞ P. 98 "Setting the Temperature of the Dryer"
[PREHEATING]	☞ P. 99 "Dryer Control While Idling"
[FEED FOR DRY]	☞ P. 100 "Drying the Trailing Edge of the Printing Area on the Dryer"
[DRYING TIME]	☞ P. 101 "Setting the Drying Time after Printing"
[ADJUST BI-DIR SIMPLE SETTING]	☞ P. 102 "Correcting for Misalignment in Bidirectional Printing"
[ADJUST BI-DIR DETAIL SETTING]	☞ P. 102 "Correcting for Misalignment in Bidirectional Printing More Precisely"
[CALIBRATION]	☞ P. 103 "Reducing Horizontal Bands (Feed Correction Function)"
[SHEET TYPE], [SHEET WIDTH], [SHEET POS.]	☞ P. 107 "Using Transparent Media"
[SCAN INTERVAL]	☞ P. 109 "Using Hard-to-Dry Media"
[VACUUM POWER]	☞ P. 109 "Using Media That Does Not Move Smoothly"
[FULL WIDTH S]	☞ P. 110 "Changing the Range of Print-head Carriage Movement"
[SIDE MARGIN]	☞ P. 111 "Expanding the Printing Area by Reducing the Margins"
[MEDIA RELEASE]	☞ P. 113 "Using Sticky Media"

☞ P. 95 "Loading a Saved Preset"

Loading a Saved Preset

Procedure

1 Press **MENU**.

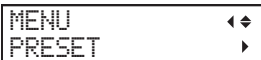
2  Press **▼** to display the screen shown on the left.
Press **▶** twice.

3  Press **▲** or **▼** to select the name of the preset you want to load.
Press **ENTER** to confirm your entry.



 The settings are changed and the screen shown on the left appears.

Description

This loads a saved preset. You can select any one of eight types of presets. (When no names have been assigned, select from among NAME1 through NAME8.) If you load a preset while **SET UP** is lit, **SET UP** starts flashing. After that, when the setup operation is complete, **SET UP** returns to being lit.

Automatic Loading of a Saved Preset When Media Is Loaded

Procedure

- 1 Press **MENU**.
- 2  Press **▼** to display the screen shown on the left. Press **▶**, then **▲**.
- 3  Press **▶**.
- 4  Press **▲** or **▼** to select "ENABLE." Press **ENTER** to confirm your entry.
- 5 Press **MENU**, then **◀** to go back to the original screen.

Description

Once "ENABLE" is selected, the screen for loading a preset is always displayed when the media is loaded. Follow the procedure given below to use the loaded preset.

How to Use the Loaded Preset

Press **SET UP** at the end of the media loading process to display the screen shown in the figure. Press **ENTER** to load the displayed preset. (Press **SET UP** before pressing **ENTER** to perform setup with the current settings without loading the preset.)



The preset displayed on the screen is the last loaded preset or the last saved preset. You can select other presets by pressing **▲** or **▼**.

Using the Dryer

What is the Dryer?

This machine is equipped with a dryer for drying the ink. You can adjust the temperature settings to match the type of media and the printing speed.

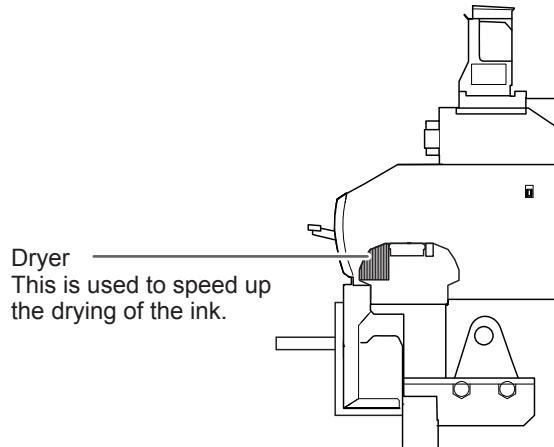

⚠️ WARNING

Caution: High temperatures

The dryer becomes hot. Exercise caution to avoid fire or burns.

⚠️ WARNING

Remove any loaded media or switch off the sub power when printing is not being performed.

The continued application of heat at a single location may cause fire or produce toxic gases.

⚠️ WARNING

Never use media that cannot withstand the heat.

Doing so may result in fire or the release of toxic gases or may degrade the media.

⚠️ WARNING

Never use the platen or dryer for any purpose for which they are not intended, such as to dry clothing.

Doing so may cause overheating, resulting in a fire or accident.

Use the machine in an environment with an ambient temperature of 20 to 32°C (68 to 90°F).

If the machine is used at an ambient temperature lower than 20°C (68°F), then depending on the type or width of the media, wrinkling or temperature-caused unevenness may occur. If this happens, try lowering the temperature of the dryer by about 2°C (36°F). To obtain stable printing results, however, use the machine in an environment with an ambient temperature of 20 to 32°C (68 to 90°F).

Note: Depending on the printing conditions, an external heater may be needed. For the details of the recommended external heater, contact your authorized Roland DG Corp. dealer. For information on how to use the external heater, refer to the documentation for the heater you are using.

Setting the Temperature of the Dryer

Procedure

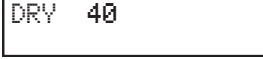
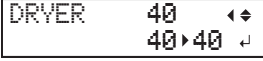
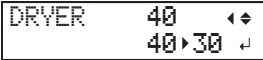
- 1 Press **HEATER**.
- 2  The current temperature is displayed.
Press **HEATER** a second time.
- 3  Press **◀** or **▶** to select the unit.
- 4  Press **▲** or **▼** to set the temperature.
You can also set the temperature to "OFF."
Press **ENTER** to confirm your entry.
- 5 Press **MENU**, then **◀** to go back to the original screen.

Temperature Setting Estimates and Hints

The optimal temperature for the dryer varies according to such factors as the type of media and differences in the print mode. Use the following as a general guide and adjust the temperature accordingly.

Dryer	When ink drying is poor, raise the temperature. Note, however, that a temperature that is too high may degrade the media or cause it to wrinkle.
Relationship between the print mode and temperature	The optimal temperature for the dryer varies according to such factors as the type of media and differences in the print mode. If smudging or poor drying occur even after raising the temperature, try using a print mode of the software RIP offering higher image quality. Conversely, if you want to use a faster print mode, raise the temperature.
Amount of ink	When you change the amount of ink using the settings for your software RIP, adjusting this may yield better results. If problems such as smudging persist even after raising the temperature, try reducing the amount of ink.
Other points to remember	When recommended settings for temperature, print mode, and other values are given as the use condition of your media, use the suggested settings.

- These are only rough estimates. Make adjustments to match the media you're using.
- Using the dryer does not necessarily make it possible to apply ink to every kind of media. Be sure to test in advance.
- Results may vary greatly depending on the print mode and other factors. Make settings suited to the media.

Description

With the default settings, simply switching on the power does not make the dryer warm up to the set temperature. The temperature rises to the set temperature when the media is loaded correctly and **SET UP** lights. You can also make this setting in the software RIP. When you have made the setting in the software RIP, the software RIP's setting is used.

* Depending on the usage environment, the temperature of the dryer may become higher than the set temperature, but this does not represent a problem.

Default Setting

[DRYER]: 40°C (104°F)

Dryer Control While Idling

Note: Preheating: State in which the main power and the sub power are switched on and **SET UP** is not lit (state in which the media setup is not completed)

Procedure

1 Hold down **MENU** and press **HEATER**.

2  Press **▶**, then **▼** to display the screen shown on the left. Press **▶**.

3  Press **▲** or **▼** to select a setting. Press **ENTER** to confirm your entry.

MENU	The system performs heating to the set temperature at all times, without lowering the temperature during preheating.
30°C(86°F)	The system maintains a temperature of 30°C (86°F) during preheating.
OFF	The dryer turns off while idling.



4 Press **MENU**, then **◀** to go back to the original screen.

Default Setting

[PREHEATING]: 30°C (86°F),

Drying the Trailing Edge of the Printing Area on the Dryer

Procedure

- 1 Hold down **MENU** and press **HEATER**.
- 2  Press **▶** to display the screen shown on the left.
Press **▶**.
- 3  Press **▲** or **▼** to select "ENABLE."
Press **ENTER** to confirm your entry.
- 4 Press **MENU**, then **◀** to go back to the original screen.

Description

- **ENABLE:** Media feeding is performed until the trailing edge of the printing area is positioned on the dryer. The margin between the print-end position and the next print-start position is set to a value of 125 mm (4.9 in.). If you set the margin to a value that is greater than or equal to the above value in the software RIP, the software's setting is used.
- **DISABLE:** Media feeding stops when printing ends. This means that the trailing edge of the printing area is not fed to the dryer unless you continue with a subsequent printing operation.

Default Setting

[FEED FOR DRY]: DISABLE

Setting the Drying Time after Printing

Procedure

- 1 Hold down **MENU** and press **HEATER**.
- 2 Press **▶**.
- 3

HEATER MENU	◀◆
DRYING TIME	▶

 Press **▲** to display the screen shown on the left.
 Press **▶**.
- 4

DRYING TIME	◀◆
0min ▶ 10min	◆

 Press **▲** or **▼** to select the drying time.
 Press **ENTER** to confirm your entry.
- 5 Press **MENU**, then **◀** to go back to the original screen.

Description

Set the drying time after the 1st page is printed. The next operation is not started until the set time passes. During drying, **PAUSE** is lit. Press **PAUSE** while **PAUSE** is lit to finish the drying time and start the next operation. Also, hold down **SET UP** while **PAUSE** is lit to cancel the output.

You can also make this setting in the software RIP. When you have made the setting in the software RIP, the software RIP's setting is used.

Default Setting

[DRYING TIME]: 0min

Fully Utilizing the Correction Function

Correcting for Misalignment in Bidirectional Printing

Procedure

1 Press **MENU**.

2 

Press **▼** several times to display the screen shown on the left.

Press **▶**.

3 

Press **ENTER**.

A test pattern is printed.

When printing ends, press **▼**, and then press **▶**.

4 

Press **▲** or **▼** to select the correction value.

Press **ENTER** to confirm your entry.

To decide a correction value

Choose the value that produces the least misalignment of the 2 lines. When you cannot choose between two numbers, select a value that is halfway between them.

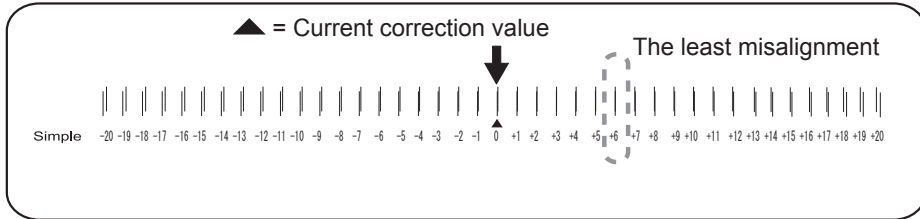

5 Press **MENU**, then **◀** to go back to the original screen.

Description

This machine prints by the bidirectional mode (in which the print head carriage performs printing during both its outbound pass and return pass). This printing method is called "Bidirectional Printing." Bidirectional printing offers the advantage of being able to shorten printing times, but subtle misalignment occurs during the outbound and return passes. The procedure to correct this and eliminate misalignment is "Bidirectional Correction." This misalignment varies according to the print head height and the thickness of the media, so we recommend performing correction to match the media you are using.

Correcting for Misalignment in Bidirectional Printing More Precisely

When further correction is required, such as when adjustment made using [SIMPLE SETTING] does not enhance printing, use [DETAIL SETTING] to make corrections.

For instructions on how to perform the work, refer to P. 40 "Performing the Initial Adjustment (Correcting for Misalignment in Bidirectional Printing More Precisely)".

Reducing Horizontal Bands (Feed Correction Function)

Procedure

1 If using roll media, check that the media is not sagging.

2 Press **MENU**.

3  Press **▼** several times to display the screen shown on the left.

Press **▼** several times to display the screen shown on the left.

Press **▶**.

4  Press **ENTER**.

Press **ENTER**.

A test pattern is printed.

When printing ends, press **▼**, and then press **▶**.

5  Press **▲** or **▼** to select the correction value.

Press **▲** or **▼** to select the correction value. Press **ENTER** to confirm your entry.

To decide a Correction Value

Select the value to make the upper/lower rectangular gap and overlap smallest. When you cannot choose between two numbers, select a value that is halfway between them.

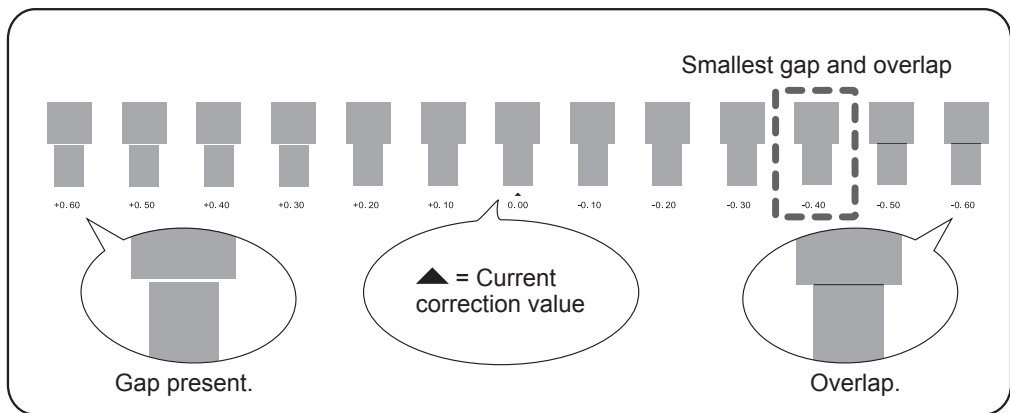

6 Press **MENU**, then **◀** to go back to the original screen.

Description

The movement distance of the media changes subtly depending on the media's thickness and the temperature of the dryer. When the movement distance becomes discrepant, horizontal stripes are more likely to occur during printing. We recommend that you make corrections to match the media you are using and the set temperature of the dryer. Repeat the process of printing a test pattern and entering a correction value several times to find the optimal value.

Depending on the software RIP you are using, you can also configure this setting in the software RIP (by, for example, choosing the media type). When you have made the setting in the software RIP, the software RIP's setting is used and the printer's setting is ignored.

Correcting Media Skew

Perform this correction when horizontal stripes cannot be eliminated even after performing the operations in P. 103 "Reducing Horizontal Bands (Feed Correction Function)".

Procedure

- 1 **If using roll media, check that the media is not being wound improperly.**
If the media is not wound correctly, fix and re-set the media.

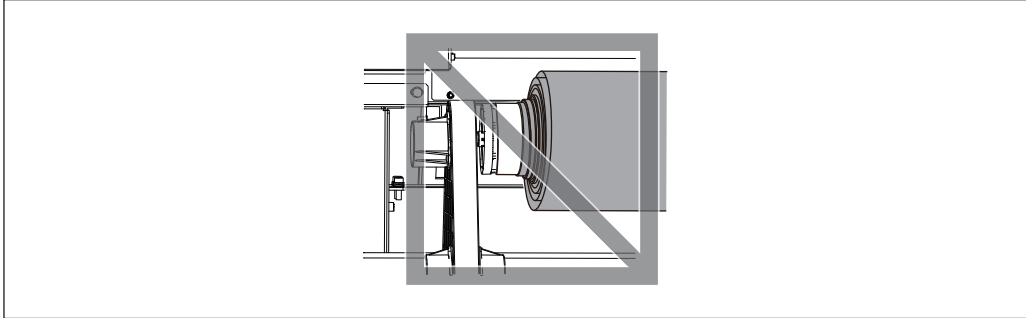



- 2 **Set [SHEET TYPE] to "OPAQUE."**

Refer to step 1 in P. 107 "Using Transparent Media" and set the [SHEET TYPE] to "OPAQUE."

- 3 **Remove the media clamps.**

- 4 **Press**  .

- 5 

Press  several times to display the screen shown on the left.

Press  .

- 6 

Press  .

A test pattern is printed.

7 Check the test results to determine the correction values.

Choose the value that produces the least misalignment of the 2 lines. When you cannot choose between two numbers, select a value between them.

"R" means "right," and "L" means "left." For example, if the line marked "L2.5" has the least misalignment, this means that there is a 2.5 mm (98.4 mil) misalignment to the left. In this case, the correction value is 2.5 mm (98.4 mil) to the right.

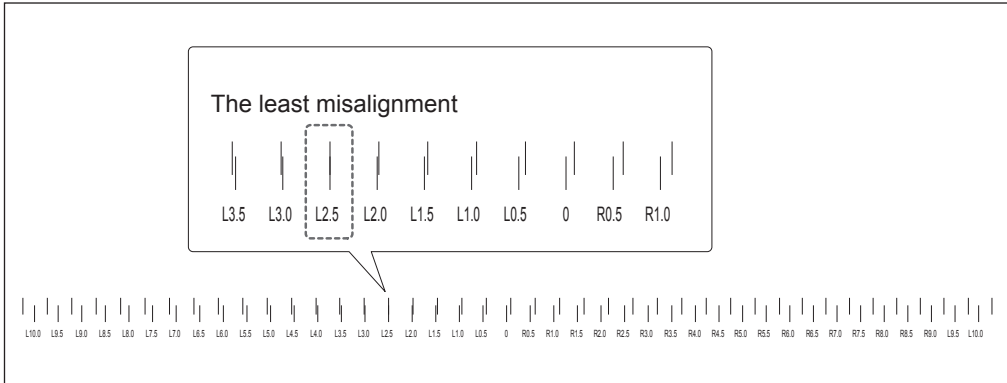
**8 Adjust the position of the media while keeping an eye on the scale on the apron.**

Raise the loading lever and adjust the position of the media based on the values determined from the test print results. Once the position has been decided, lower the loading lever to secure the position of the media.

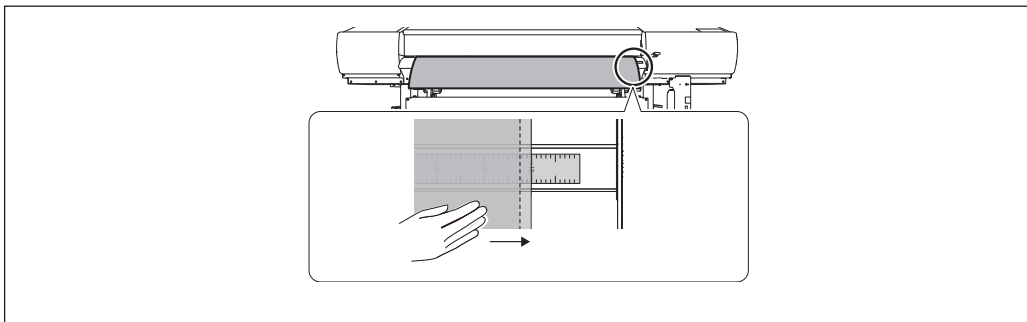
**9 Repeat from step 4 to 6 once more to check the correction results.**

Adjustment is complete when the two lines align at the "0" position. If the two lines do not align at the "0" position, adjust the position of the media once more.

Description

Even if the media is attached straight, it may drift diagonally through subtle shifts. If the media drifts, horizontal stripes are more likely to occur during printing. This function reduces horizontal bands by correcting the skew of the media.

If the media is 5 mm (196.9 mil) or more to the right from the test pattern printing start location, an error will be generated and the test pattern will not print. Move the media 5 mm (196.9 mil) or more to the left.

Accommodating Different Media Types and Conditions

Adjusting Print Head Height to Match Media Thickness

Procedure

1 Press **MENU**.

2 

Press  several times to display the screen shown on the left.

Press .

3 

When the screen shown on the left is displayed, open the front cover.

4 **Move the height-adjustment lever to adjust the print-head height.**

When the lever is moved to the "High" direction, the buzzer sounds twice. When it is moved to the "Low" direction, the buzzer sounds once.

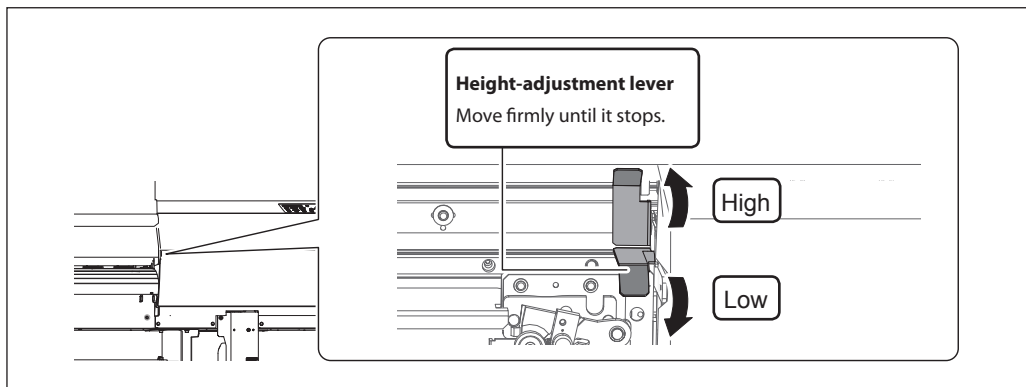

5 

Close the front cover.

The print-head carriage moves to the original position, and then the screen shown on the left appears.

6 Press **MENU**, then  to go back to the original screen.

Description

Depending on the media, media may wrinkle or come loose from the platen during printing, increasing the chance of contact with the print heads. When you are using such media, adjust [HEAD HEIGHT] to "HIGH." Printing quality when [HEAD HEIGHT] is set to "HIGH" may be coarser or otherwise lower than when set to "LOW." If this happens, refer to the pages indicated below.

☞ P. 102 "Correcting for Misalignment in Bidirectional Printing", P. 40 "Performing the Initial Adjustment (Correcting for Misalignment in Bidirectional Printing More Precisely)", P. 112 "Preventing Soiling of the Media and Dot Drop-Out"

Using Transparent Media

1. Set the media type to "CLEAR."

1 Raise the loading lever.

2 Press **MENU**.

3 

Press  several times to display the screen shown on the left.

Press  twice.

4 

Press  or  to select "CLEAR."

Press  to confirm your entry.

2. Set the media width.

1 

Press  to display the screen shown on the left.

Press .

2 

Press .

3 

Press  or  to enter the width of the media.

Press  to confirm your entry.

4 Press **MENU**, then  to go back to the original screen.

3. Load transparent media on the machine.

Refer to P. 21 "Loading Media", and load the media on the machine.

4. Set the position of the right edge of the media.

1 Press **MENU**.

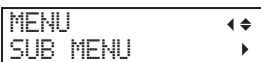
2 

Press  several times to display the screen shown on the left.

Press .

3 

Press  twice to display the screen shown on the left.

Press .



The print-head carriage moves to the currently set position, and then the screen shown on the left appears.

4

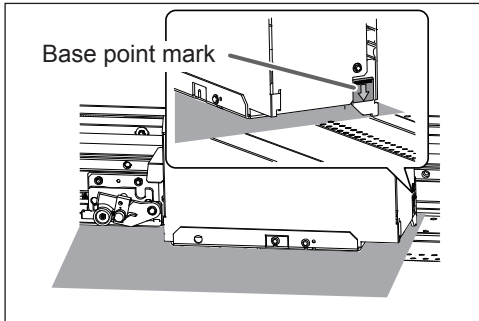

Press or to move the print-head carriage (base point mark) to the right edge of the media.

The position indicated by the arrow of the base point mark is set as the position of the right edge of the media

If a fixed period of time passes while the setting procedure is in progress, the menu is forcefully terminated.

If a fixed period of time passes while the setting procedure is in progress, the menu is forcefully terminated and the print-head carriage returns to the home position to prevent the print heads from drying out. In this case, perform step 4. again.

To quit the procedure for setting the position of the right edge of the media

1 Close the front cover.

2 Press to display the screen shown on the left.

3 Press .

The print-head carriage returns to the home position (behind the right cover).

5 After positioning, press to confirm your entry.

Description

For transparent media, the width and position cannot be automatically detected. Therefore, [SHEET TYPE] must be set to "CLEAR" before the width and attachment position are set manually.

When [SHEET TYPE] is set to "CLEAR," printing does not stop if the media runs out while printing is in progress. If media runs out while printing is in progress, immediately press to stop printing. Otherwise, there is a chance that the platen or other parts may become soiled by ink or that ink may get inside and damage the machine.



Default Settings

[SHEET TYPE]: OPAQUE

[SHEET WIDTH]: 1,625 mm (64 in.)

Using Hard-to-Dry Media

Procedure

- 1 Press **MENU**.
- 2  Press **▼** several times to display the screen shown on the left.
Press **▶**.
- 3  Press **▼** several times to display the screen shown on the left.
Press **▶**.
- 4  Press **▲** or **▼** to select a value.
Larger values cause the media to move more slowly, enabling you to extend the drying time accordingly.
Press **ENTER** to confirm your entry.
- 5 Press **MENU**, then **◀** to go back to the original screen.

Description



Use this if ink dries poorly even when the dryer is used. Depending on the software RIP you are using, you can also make this setting in the software RIP. When you have made the setting in the software RIP, the printer's setting is ignored.

Default Setting

[SCAN INTERVAL]: OFF

Using Media That Does Not Move Smoothly

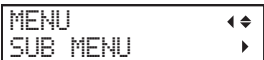
Procedure

- 1 Press **MENU**.
- 2  Press **▼** several times to display the screen shown on the left.
Press **▶**.
- 3  Press **▼** several times to display the screen shown on the left.
Press **▶**.

- 4 Press or to select a value.
Press to confirm your entry.

0%–100%	When the media is flimsy and cannot move smoothly, decreasing this value (reducing the suction force) may resolve the problem.
AUTO	The strongest suction force will always be used.

- 5 Press , then to go back to the original screen.

Description

The platen uses suction to grip the media and keep it stable. The suction force can be adjusted corresponding to the nature and condition of the media. Depending on the software RIP you are using, you can also make this setting in the software RIP. When you have made the setting in the software RIP, the machine's setting is ignored.

Default Setting

[VACUUM POWER]: AUTO

4

Changing the Range of Print-head Carriage Movement

Procedure

- 1 Press .
- 2 Press several times to display the screen shown on the left.
Press .
- 3 Press several times to display the screen shown on the left.
Press .
- 4 Press or to select a setting.
Press to confirm your entry.

SHEET	"SHEET" matches the range of print head movement to the width of the media.
OFF	"OFF" matches the range of print head movement to the printing data. Movement is limited to the minimum amount necessary, and this can be expected to yield the fastest output. Note, however, that because the speed of media movement is no longer constant, colors may be uneven.
FULL	"FULL" makes the speed of media movement constant at all times and produces the most stable printing result.

- 5 Press , then to go back to the original screen.

Description

Fixing the width that the print-head carriage moves can help reduce uneven colors. When this setting is set to "OFF," the movement of the print-head carriage is minimized. This does save printing time, but because the speed of media movement is no longer constant, colors may be uneven.

Default Setting

[FULL WIDTH S]: FULL

Expanding the Printing Area by Reducing the Margins

Procedure

1 Press **MENU**.

2 

Press **▼** several times to display the screen shown on the left.

Press **▶**.

3 

Press **▼** several times to display the screen shown on the left.

Press **▶**.

4 

Press **▲** or **▼** and select "5mm."

Press **ENTER** to confirm your entry.

5 Press **MENU**, then **◀** to go back to the original screen.

Description

This makes the setting for distance from the left or right media clamp to the corresponding left or right edge of the printing area. You can select "5 mm," "10 mm," or "25 mm." Setting this to "5 mm" lets you expand the printing area.

☞ P. 148 "Maximum Printing Area and Margins"

Note, however, that when you are using transparent media, setting this to "5 mm" may result in printing on top of the media clamps.

Default Setting

[SIDE MARGIN]: 10 mm

Preventing Soiling of the Media and Dot Drop-Out

Procedure

- 1 Press **MENU**.
- 2

MENU	◀▶
SUB MENU	▶

 Press **▼** several times to display the screen shown on the left. Press **▶**.
- 3

SUB MENU	◀▶
PERIODIC CL.	▶

 Press **▼** several times to display the screen shown on the left. Press **▶**.
- 4

PERIODIC CL.	◀▶
NONE	↵

 Press **▲** or **▼** to select a setting. Press **ENTER** to confirm your entry.

NONE	Automatic cleaning is not performed.
PAGE	Automatic cleaning is performed every time before printing starts.
INTERVAL (JOB)	Automatic cleaning is performed when the cumulative printing time reaches the value you set here. However, if this time is reached during printing, automatic cleaning is performed before the next printing operation starts. Because printing is not paused, uneven color issues due to paused operation do not occur.
INTERVAL (TIME)	Automatic cleaning is performed when the cumulative printing time reaches the value you set here. When this time is reached during printing, printing pauses and so colors may be uneven.

- 5 Press **MENU**, then **◀** to go back to the original screen.

Description

In the following cases, ink tends to collect on the surface of the print heads. Under some conditions, this ink may be transferred to the media or cause dot drop-out.

- When you use media prone to static electricity buildup.
- When the ambient temperature is low.
- When the print-head height is set to "HIGH."



If "PAGE," "INTERVAL (JOB)," or "INTERVAL (TIME)" is selected, ink buildup is removed before or during printing. Note, however, that using these settings results in longer printing times.

Default Setting

[PERIODIC CL.]: NONE

Using Sticky Media

Procedure

- 1 Press **MENU**.
- 2  Press **▼** several times to display the screen shown on the left.
Press **▶**.
- 3  Press **▼** several times to display the screen shown on the left.
Press **▶**.
- 4  Press **▲** or **▼** to select "ENABLE."
Press **ENTER** to confirm your entry.
- 5 Press **MENU**, then **◀** to go back to the original screen.

Description

Some types of media may tend to stick to the platen. Starting printing with the media sticking to the platen may make normal media feed impossible and cause the media to jam. When using such media, set the [MEDIA RELEASE] menu item to "ENABLE." This peels off the media before starting printing if it is stuck to the platen. Note, however, that media feed may be unstable when printing is performed after executing this operation. Leave this menu item set to "DISABLE" unless you specifically need to change it.

Default Setting

[MEDIA RELEASE]: DISABLE

Printing with Crop Marks

Printing with Crop Marks

Use your software RIP to configure the settings for printing crop marks. For information on how to make the settings, refer to the documentation for the software RIP you are using.

IMPORTANT!

Alignment marks and symbols drawn using graphics software cannot be used as crop marks.

Using the Media Take-Up System

Using the Media Take-up System

- The media take-up system ("take-up system") is an optional item.
- For information on how to assemble and install the take-up system, refer to the user's manual of the take-up system.
- In this manual, instructions for loading media assume that the TUC-3 will be used.
 - ☞ From P. 28 "Load a paper tube onto the take-up system, and switch on the take-up system power." to P. 34 "Secure the media on the paper tube (core)."

Important Notice When Using the TUC-3

- If using the TUC-3 with this machine, it is necessary to make adjustments such as by removing the springs from the control box and frame of the TUC-3. For details, refer to TUC-3 documentation.

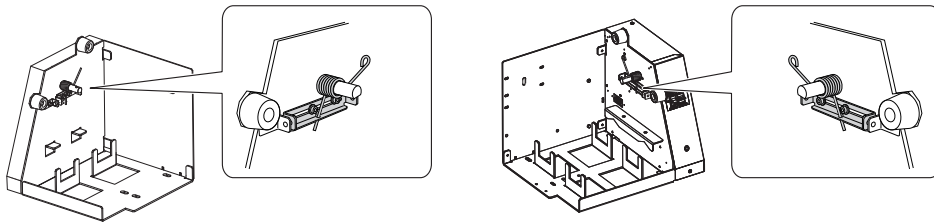

- If using the TUC-3 with this machine, do not press  and feed the media in the reverse direction. It may cause an error because the media is pulled with excessive force.
 - ☞ P. 144 "[MOTOR ERROR TURN POWER OFF]"

Chapter 5

To Administrators



Output Operation Management	118
Printing a System Report	118
Determining What Happens When Ink Runs Out.....	118
Displaying the Amount of Media Remaining	119
Making Sure to Verify the Setting for the Amount Remaining Every Time the Media Is Changed.....	120
Printing the Amount of Remaining Media.....	121
System Management of Printer	122
Setting Menu Language and Units of Measurement.....	122
Setting Activation Interval for Sleep Mode (Power-Saving Feature).....	122
Viewing System Information.....	123
Returning All Settings to Their Factory Default Values	124
Changing Installation Location.....	125

Output Operation Management

Printing a System Report

This prints system information, including a list of setting values.



Procedure

- 1 Press **MENU**.
- 2  Press **▼** several times to display the screen shown on the left.
Press **▶**.
- 3  Press **▼** several times to display the screen shown on the left.
Press **ENTER**.
Printing starts.
- 4 Press **MENU** to go back to the original screen.

Determining What Happens When Ink Runs Out

This lets you change, according to your purpose, the operation that takes place when a subtank cartridge is empty.

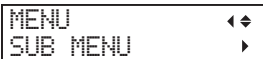
Procedure

- 1 Press **MENU**.
- 2  Press **▼** several times to display the screen shown on the left.
Press **▶**.
- 3  Press **▲** several times to display the screen shown on the left.
Press **▶** twice.
- 4  Press **▲** or **▼** to select a setting.
Press **ENTER** to confirm your entry.

STOP	Printing pauses immediately when a subtank cartridge becomes empty.
CONT. (continue)	Printing does not stop when a subtank cartridge becomes empty. When a subtank cartridge becomes empty, a warning beep sounds.

- 5 Press **MENU** to go back to the original screen.

Description

When "STOP" is selected, printing pauses, so colors may be uneven. Ensure that the remaining ink is sufficient before you begin printing. When "CONT" is selected, printing does not stop even if ink runs out completely. To replace an ink pouch, wait until printing ends or press **PAUSE** to pause printing.





Default Setting

[EMPTY MODE]: STOP

Displaying the Amount of Media Remaining

You can display how much of the media in use is left. By setting the amount of media currently remaining at the start, the amount remaining will be constantly displayed on the display screen until it reaches zero.

Procedure

- 1 Press **MENU**.
- 2  Press **▲** to display the screen shown on the left. Press **▶**, then **▼**.
- 3  Press **▶**.
- 4  Press **▲** or **▼** to set the current amount of media remaining. Press **ENTER** to confirm your entry.
- 5  Press **MENU**, then **◀** to go back to the original screen.

This display is updated.

 If media has not been loaded, the set value flashes.

Description













If you cancel media loading, for example by removing the media or raising the loading lever, the amount remaining at that time flashes on the screen. Because the amount of media remaining is not updated automatically when you change the media, redo the setting whenever you change the media. You can also set the machine to display this menu automatically whenever you change the media. See the next section, "Making Sure to Verify the Setting for the Amount Remaining Every Time the Media Is Changed."

* The remaining amount that is displayed is only an estimate. Accuracy is not assured.

Making Sure to Verify the Setting for the Amount Remaining Every Time the Media Is Changed

Set the machine to display  every time the media is changed.

Procedure

- 1 Press .
- 2  Press  to display the screen shown on the left.
Press .
- 3  Press  twice to display the screen shown on the left.
Press .
- 4  Press  or  to select "ENABLE."
Press  to confirm your entry.
If you select "ENABLE," you must set the [SHEET TYPE] menu item to "OPAQUE."
☞ P. 107 "Using Transparent Media"
- 5 Press , then  to go back to the original screen.

Description

Setting this menu to "ENABLE" can keep you from forgetting to redo the setting when you change the media. However, be sure to also set the [SHEET TYPE] menu item to "OPAQUE" (P. 107 "Using Transparent Media"). When [SHEET TYPE] is set to "CLEAR," [SHEET REMAIN] is not displayed automatically.



Default Setting

[AUTO DISPLAY]: DISABLE

Printing the Amount of Remaining Media

This prints the amount of media remaining that is displayed at the top menu.

Procedure

- 1 Press **MENU**.
- 2  Press **▲** to display the screen shown on the left.
Press **▶**.
- 3  Press **ENTER**.
Printing starts.
- 4 Press **MENU**, then **◀** to go back to the original screen.

Description

Use this when you want to make a record of the remaining length of the media currently in use. Printing the amount of media remaining before you change the media enables you to refer to the printed record and use the value to make the setting for the remaining amount the next time you use the media.



Note, however, that if you continue printing, the next printing operation will start on top of the portion where the amount of remaining media is printed. If you want to continue printing, cut off the media before starting the next printing operation.

System Management of Printer

Setting Menu Language and Units of Measurement

This sets the language and units of measurement displayed on the display screen of the operation panel.

Procedure

- 1 Hold down **MENU** and switch on the sub power.
- 2  Press **▲** or **▼** to select the display (menu) language.
Press **ENTER** to confirm your entry.
- 3  Press **▲** or **▼** to select the measurement unit for length.
Press **ENTER** to confirm your entry.
- 4  Press **▲** or **▼** to select the measurement unit for temperature.
Press **ENTER** to confirm your entry.

Default Setting



[MENU LANGUAGE]: ENGLISH

[LENGTH UNIT]: mm

[TEMP. UNIT]: °C

Setting Activation Interval for Sleep Mode (Power-Saving Feature)

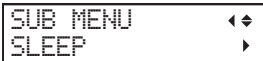
Procedure

- 1 Press **MENU**.
- 2  Press **▼** several times to display the screen shown on the left.
Press **▶**.
- 3  Press **▲** several times to display the screen shown on the left.
Press **▶** twice.
- 4  Press **▲** or **▼** to select a setting.
Press **ENTER** to confirm your entry.
- 5 Press **MENU** to go back to the original screen.

Default Setting

[INTERVAL]: 30 min

5

To Admin-
istrators

Viewing System Information

Note: For information on how to set up a network, see the "Setup Guide."

Procedure

1 Press **MENU**.



Press **▲** several times to display the screen shown on the left.

You can view the following information:

[MODEL]: Model name

[SERIAL NO.]: Serial number

[INK]: Ink type

[FIRMWARE]: Firmware version

[NETWORK]: Network settings such as the IP address

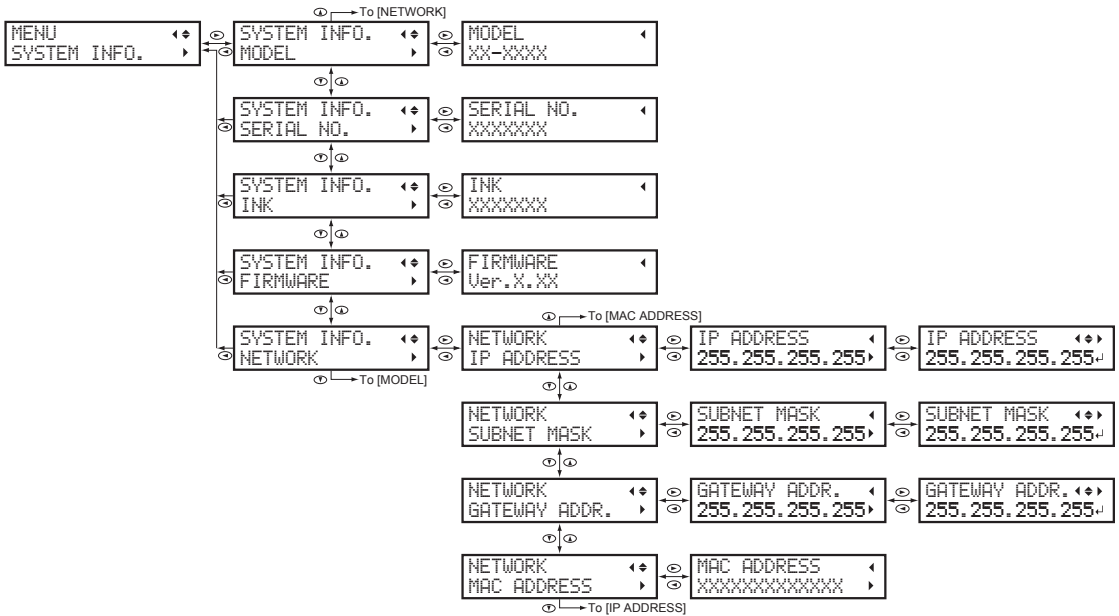

Returning All Settings to Their Factory Default Values

This menu returns all settings to their factory defaults. However, the settings for [MENU LANGUAGE], [LENGTH UNIT], and [TEMP. UNIT] are not returned to their factory default values.

Procedure

1 Press **MENU**.

2 

Press **▼** several times to display the screen shown on the left.

Press **▶**.

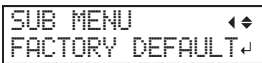
3 

Press **▼** several times to display the screen shown on the left.

Press **ENTER** to execute.

Changing Installation Location

Before changing the installation location of the machine, consult your authorized Roland DG Corporation dealer. Roland service technician will move the machine and make adjustments afterwards.

* The feed adjuster must be adjusted after the machine has been moved even if it has only been moved a short distance, e.g., to a different location on the same floor.

Chapter 6

Read This Chapter Whenever You Face a Problem (FAQ)

Attractive Printing is Impossible	128
Printed Results Are Coarse or Contain Horizontal Stripes	128
Colors Are Unstable or Uneven.....	129
The Media Becomes Soiled When Printed	130
Color Mixing Occurs.....	131
A Media Jam Occurs!.....	132
The Media Has Jammed.....	132
Media Feed Is Not Smooth	133
Media Wrinkles or Shrinks	133
Media Feeding Is Not Straight.....	134
Media Feeding Is Not Smooth.....	134
Why Has the Print-Head Carriage Stopped Moving?	135
What to Do First	135
If the Print-Head Carriage Still Do Not Move	135
Other Problems.....	137
The Machine Does Not Move.....	137
Cannot Cut Off the Media	139
Dryer Does Not Become Hot.....	139
It Is Not Possible to Check the Amount of Discharged Fluid in the Drain Bottle ..	139
A Message Appears	140
An Error Message Appears.....	142

Printed Results Are Coarse or Contain Horizontal Stripes

Do the print heads show dot drop-out?

Carry out a printing test and make sure no dot drop-out occurs. If dot drop-out is present, perform cleaning of the print heads.

☞ P. 49 "Printing Tests and Normal Cleaning", P. 67 "When Normal Cleaning Is Not Effective"

Are the settings for the [PRESET] menu item appropriate?

If the settings selected with the [PRESET] menu item are not suitable for the type of media, printing may be adversely affected. Choose settings optimized to the media you are using.

☞ P. 42 "Setup of Media ("MEDIA SETTING" menu)", P. 94 "Fully Utilizing the Preset Function"

Have you carried out bidirectional correction?

When you are performing bidirectional printing, use the [ADJUST BI-DIR] menu item to carry out correction. The optimal adjustment value may vary depending mainly on the thickness of the media. Set or select an adjustment value that is suitable for the media. When further correction is required, such as when adjustment made using [SIMPLE SETTING] does not enhance printing results, use [DETAIL SETTING] to carry out correction.

☞ P. 102 "Correcting for Misalignment in Bidirectional Printing", P. 102 "Correcting for Misalignment in Bidirectional Printing More Precisely"

Have you carried out feed correction?

Large misalignment in the amount of feed of the media may result in printing results that seem coarse or contain horizontal stripes. Either make the setting in the software RIP to match the type of media you are using, or make the setting for correction on the machine.

☞ P. 103 "Reducing Horizontal Bands (Feed Correction Function)"

Is the print head height appropriate?

Printing when the [HEAD HEIGHT] menu item is set to "HIGH" produces coarser printing results than when set to "LOW." Keep this set to "LOW" except when changing it is necessary, such as when you are using thick media.

☞ P. 106 "Adjusting Print Head Height to Match Media Thickness"

Is the dryer at a suitable temperature?

If the ink forms lumps or smudges, raise the temperature. Note, however, that a temperature that is too high may degrade the media or cause it to wrinkle.

☞ P. 98 "Setting the Temperature of the Dryer"

Is the temperature of the room too low?

The media heating system may not warm up sufficiently when the ambient temperature is less than 20°C (68°F). Also, even when the media heating system reaches its set temperatures, adequate effectiveness may not be apparent if the media is thoroughly chilled. Before printing, allow the media to come to room temperature.

Is the print mode suitable?

Try a higher quality print mode. Depending on the media, smudging may occur when using a high-quality print mode, and results may also vary greatly depending on the settings of your software RIP (such as the color-profile selection). Make settings suited to the media you are using.

Is the media loaded correctly?

If the media is not loaded correctly or media feed is not smooth, printing results may be adversely affected. Load the media correctly.

☞ P. 21 "Loading Media", P. 133 "Media Feed Is Not Smooth"

Is the machine installed in a level and stable location?

Never install the machine in a location where it is tilted or where it may wobble or experience vibration. Also make sure that the print heads are not exposed to moving air. Failure to do so may cause dot drop-out or adversely affect printing results.

Are the ink pouches installed appropriately?

If an ink pouch is not installed appropriately, printing results may be adversely affected.

☞ P. 61 "Ink Pouch Replacement"

Did you pause printing?

When printing is paused, the coloring at the seam may be altered when printing resumes. Avoid pausing printing. Under factory default settings, printing pauses when an ink pouch runs out. Before you perform lengthy printing, check the amount of ink remaining in the ink pouches. Printing may also pause when data is not sent from the computer quickly enough. We recommend not performing any other tasks with the computer while printing is in progress.

Colors Are Unstable or Uneven

Are the settings for the [PRESET] menu item appropriate?

If the settings selected with the [PRESET] menu item are not suitable for the type of media, printing may be adversely affected. Choose settings optimized to the media you are using.

☞ P. 94 "Fully Utilizing the Preset Function"

Are the operating parameters set to appropriate values?

Depending on the settings for such menu items as [FULL WIDTH S] and [PERIODIC CL.], uneven colors may occur. If the settings have been changed, try restoring them to their factory default values.

☞ P. 110 "Changing the Range of Print-head Carriage Movement", P. 112 "Preventing Soiling of the Media and Dot Drop-Out"

Is the media loaded correctly?

If the media is not loaded correctly or media feed is not smooth, printing results may be adversely affected. Load the media correctly.

☞ P. 21 "Loading Media", P. 133 "Media Feed Is Not Smooth"

Did you shake the ink pouches gently before installing them?

Shake a new ink pouch before installing it.

☞ P. 60 "Ink Pouch Replacement"

Is the media wrinkled?

If the media is wrinkled and comes loose from the platen, colors may be uneven or printing results may be adversely affected.

☞ P. 133 "Media Wrinkles or Shrinks"

Have you not printed for a while?

If printing is not performed for several days, printed colors may become unstable or uneven, e.g., when color density is inconsistent, even if the same data is printed with the same settings.

In such cases, shaking the ink pouches, performing light choke cleaning, and refreshing the sub tanks can be effective. (The light choke cleaning and sub tank refresh procedures consume large quantities of ink. Read the instructions in this manual carefully and undertake these procedures with caution.)

☞ P. 69 "If Colors Are Uneven", P. 78 "Refreshing Sub tanks (REFRESH SUBTANKS)"

Is the machine installed in a level and stable location?

Never install the machine in a location where it is tilted or where it may wobble or experience vibration. Also make sure that the print heads are not exposed to moving air. Failure to do so may cause dot drop-out or adversely affect printing results.

The Media Becomes Soiled When Printed

Are the print heads dirty?

The following may cause ink to drip on the media during printing:

- **Buildup of fibrous dust (lint) around the print heads**
- **Ink transferred to the print heads due to rubbing against the media**
If this happens, perform manual cleaning. We recommend carrying out periodic print head cleaning.
☞ P. 72 "Manual Cleaning"
- **Too low humidity**
Use the machine in an environment of 35 to 65% RH (no condensation).

Are the pinch rollers or the media clamps dirty?

Periodically clean them.

☞ P. 65 "Cleaning"

Do the print heads come into contact with the media?

The height of the print heads may be too low. Also, if the media is not loaded correctly, it may wrinkle or come loose and strike the print heads.

☞ P. 106 "Adjusting Print Head Height to Match Media Thickness", P. 133 "Media Feed Is Not Smooth"

Color Mixing Occurs

Has an ink pouch of the wrong color been installed by mistake?

As soon as an ink pouch is installed, ink flows out of the ink pouch into the ink path. Therefore, if an ink pouch is installed incorrectly, ink mixes inside the ink path even if the pouch is removed immediately. In the event you install an ink pouch of the wrong color, refresh the subtanks. If this fails to resolve issues with color mixing, contact your authorized Roland DG Corporation dealer.

☞ P. 78 "Refreshing Subtanks (REFRESH SUBTANKS)"

A Media Jam Occurs!

The Media Has Jammed

If an error message is displayed because the media has jammed, immediately correct the problem. Failure to do so may damage the print heads.

☞ P. 144 "[MOTOR ERROR TURN POWER OFF]"

Are the grit rollers dirty?

Check to make sure the grit rollers are free of buildup of foreign material such as media scraps.

☞ P. 65 "Cleaning"

Is the height of the print heads too low?

Try raising the print heads higher. Media may inevitably warp or wrinkle slightly, so adjust the height of the print heads to take this into account.

☞ P. 106 "Adjusting Print Head Height to Match Media Thickness"

Are the media clamps mounted?

When you are performing printing, be sure to attach the media clamps.

Is the media loaded straight and securely?

Feed is not smooth when the media is not straight or is tensioned unevenly on the left and right. Reload the media.

☞ P. 21 "Loading Media"

Is some other object coming into contact with the media?

Make sure that nothing touches the media.

☞ P. 21 "Loading Media"

Is the media too thick?

Media that is too thick may not only cause an unstable feed but may scrape the print heads, resulting in a malfunction. Never use such media.

Is the media warped or wrinkled?

Many factors can cause warping or wrinkling. Refer to the following and correct the problem.

☞ P. 133 "Media Wrinkles or Shrinks"

Media Feed Is Not Smooth

A variety of problems can occur if the media feed is not smooth. This can cause such problems as poor printing results, contact with the media by the print heads, misaligned positioning, or media jams. Take action as follows.

Media Wrinkles or Shrinks

Are the media clamps attached?

When you are performing printing, be sure to attach the media clamps.

Is the media loaded straight and securely?

Feed is not smooth when the media is not straight or is tensioned unevenly on the left and right. Reload the media.

☞ P. 21 "Loading Media"

Was loaded media allowed to stand for some time?

Media may shrink or wrinkle if it is heated for an extended time. When printing ends, switch off the sub power or remove the media. Store removed media in a suitable environment.

☞ P. 19 "Media Storage Environment"

Is the media sagging?

If sagging media is used, it may come out wrinkled.

Is the temperature of the dryer too high?

Set the temperature to suitable values for the type of media.

☞ P. 97 "Using the Dryer"

Is the temperature of the room too low?

Use the machine in an environment with an ambient temperature of 18 to 25°C (64 to 77°F). If the machine is used at an ambient temperature of less than 18°C (64°F), then depending on the type or width of the media, wrinkling or temperature-caused unevenness may occur. To obtain stable printing results, use the machine in an environment with an ambient temperature of 18 to 25°C (64 to 77°F).

Is the humidity of the room too high?

Use the machine in an environment of 35 to 65% RH (no condensation).

Media Feeding Is Not Straight

Are the grit rollers dirty?

Check to make sure the grit rollers are free of buildup of foreign material such as media scraps.

☞ P. 65 "Cleaning"

Is the media loaded straight and securely?

Feed is not smooth when the media is not straight or is tensioned unevenly on the left and right. Reload the media.

☞ P. 21 "Loading Media"

Is some other object coming into contact with the media?

Make sure that nothing touches the media.

☞ P. 21 "Loading Media"

Is the media too thick?

Media that is too thick may not only cause an unstable feed but may scrape the print heads, resulting in a malfunction. Never use such media.

Media Feeding Is Not Smooth

Are the grit rollers dirty?

Check to make sure the grit rollers are free of buildup of foreign material such as media scraps.

☞ P. 65 "Cleaning"

Is some other object coming into contact with the media?

Make sure that nothing touches the media. This may adversely affect printing results, even when feed appears to be smooth.

☞ P. 21 "Loading Media"

Is the media too thick?

Media that is too thick may not only cause an unstable feed but may scrape the print heads, resulting in a malfunction. Never use such media.

Why Has the Print-Head Carriage Stopped Moving?

If the print-head carriage stops over the platen, take action immediately to prevent the print heads from drying out.

What to Do First

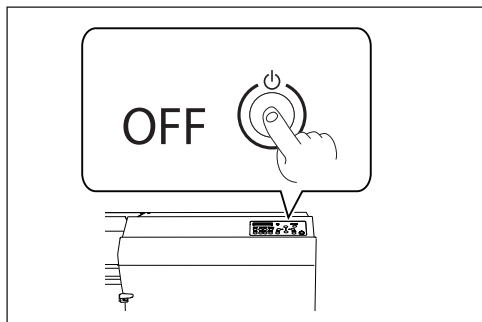

Switch the sub power off and then back on again.

If the media is jammed, also remove the media.

If the print-head carriage moves to the home position (inside the right cover), it means the operation has ended successfully.

If the print-head carriage still does not move

Try switching off the main power, then again switching on the main power, followed by the sub power.

If the Print-Head Carriage Still Do Not Move

If the print-head carriage still do not move, carry out the following emergency response measure, and then contact your authorized Roland DG Corp. dealer.

Procedure

- 1 Switch off the main power and open the front cover.
- 2 Remove the right cover.

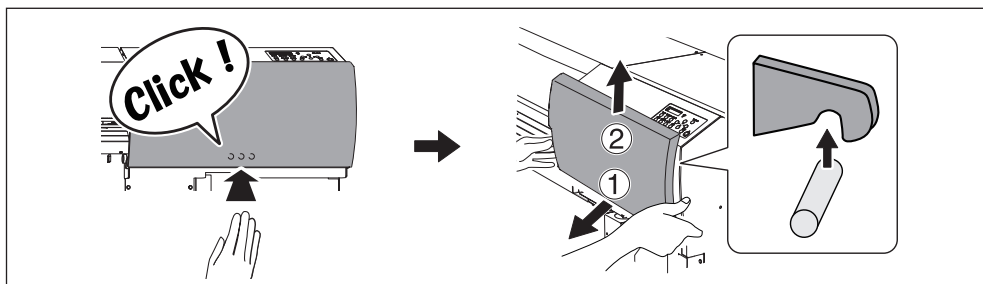

3

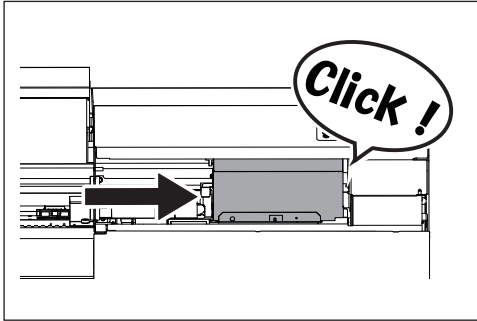

Gently move the print-head carriage to the home position by hand.

Stopping at the place where the audible click is heard locks the print-head carriage in place.

4

Gently apply pressure from the right side to make sure the print-head carriage does not move to the left.

If the print-head carriage moves to the left, move it again slowly by applying pressure from the left side and make sure it locks in place.

Other Problems

The Machine Does Not Move

Are the cables connected?

Connect the cables securely.

☞ "Setup Guide"

Is the power switched on?

Switch on the machine's main power, then press the sub power switch and make sure the sub power switch lights up.

☞ P. 20 "Switch On!"

Is a cover open?

Close the front, left, and right covers.

Is **SET UP** illuminated?

Printing is not performed when **SET UP** is not illuminated. Lower the loading lever.

☞ P. 52 "Getting Ready to Receive Data from a Computer"

Is the top menu displayed?

Top menu



If the top menu is not displayed, printing does not start even when data is sent from the computer. To go to the top menu, press **MENU**, and then press **◀**.

☞ P. 52 "Getting Ready to Receive Data from a Computer"

Is a message displayed on the screen?

☞ P. 140 "A Message Appears", P. 142 "An Error Message Appears"

Is **PAUSE** illuminated?

When **PAUSE** lights up, operation is paused. To resume, press **PAUSE**. **PAUSE** goes dark and printing resumes.

☞ P. 54 "Pausing or Canceling Printing"

Has the ink run out?



When the screen shown above is displayed, print data cannot be accepted.

If the screen shown above is displayed during printing, the behavior of the machine depends on the [EMPTY MODE] setting.

- When "STOP" is selected: The printing operation is paused.
 - When "CONT." is selected: A warning beep sounds and printing continues until the machine has finished printing the print data it has received. In this case, it is also possible to press **PAUSE** and pause printing.
- In both cases, the error can be resolved by replacing the ink pouch with a new one. If there is print data that has not yet been printed remaining in the machine, printing resumes. If there is unsent print data in the computer, printing resumes when the data is resent.

☞ P. 61 "Ink Pouch Replacement", P. 118 "Determining What Happens When Ink Runs Out"

If you are using the media take-up system (TUC-3), does the media move when pressing and holding **▲**?

If you are using the separately sold media take-up system (TUC-3), pressing and holding **▲** to move the media will cause the machine to stop for a certain length of time.

☞ P. 144 "[MOTOR ERROR TURN POWER OFF]"

Is the network routing appropriate?

Check whether the network routing is appropriate. Try connecting the computer and the machine to the same hub, or connecting them directly using a crossover cable. If this makes it possible to perform printing, it means the problem is in the network itself.

Are the network settings correct?

If the cable connections are secure and no problem is found in the network itself, make sure that the IP address and other such settings are appropriate. The settings on both the machine and the computer must be appropriate. Redo the settings while checking to ensure that the IP address does not conflict with the IP address for another device on the network, that the port setting for the software RIP specifies the IP address set on the machine, that the settings have no typing errors, and for other such problems.

☞ "Setup Guide," P. 123 "Viewing System Information"

Did the software RIP end abnormally?

Make sure the software RIP is running correctly, then switch the machine's sub power switch off and back on. For information about using the software RIP, refer to the documentation included with the software RIP.

Cannot Cut Off the Media

Is the separating knife installed?

If the separating knife is not installed, you cannot cut off the media.

☞ P. 89 "Replacing the Separating Knife"

Is the cut rail installed?

If the cut rail is not installed, you cannot cut off the media. The cut rail is removed when performing manual cleaning. If the cut rail is not installed, remove the left cover, and then install the cut rail by following step 4 in P. 77 "Reattach the left and right covers, and finish manual cleaning mode.". After installing the cut rail, be sure to attach the left cover.

Dryer Does Not Become Hot

Is the media loaded?

The media heating system does not warm up to the set temperature when **SET UP** is off (by default). Load the media and wait for the machine to warm up.

☞ P. 97 "Using the Dryer"

Is the temperature of the room too low?

Use the machine in an environment where the temperature is 20 to 32°C (68 to 90°F).

It Is Not Possible to Check the Amount of Discharged Fluid in the Drain Bottle

Is ink splattered around the inside of the drain bottle?

If ink is splattered around the inside of the drain bottle, it may not be possible to check how much discharged fluid the bottle contains.

☞ P. 64 "If It Is Not Possible to Check the Amount of Discharged Fluid in the Drain Bottle"

A Message Appears

These are the main messages that appear on the machine's display to prompt correct operation. They do not indicate any errors. Follow the prompts and take action accordingly.

[PRESS THE ENTER KEY TO CONTINUE OPERATION]

If the front cover, left cover, or right cover (hereafter collectively referred to as "covers") is opened during printing or any other operation where the print-head carriage is moving, the printer will perform an emergency stop.

☞ P. 142 "[CLOSE COVER (FRONT COVER/COVER L/COVER R)]"

When an emergency stop occurs, a message requesting the covers be closed will be displayed on the screen. Close the covers as directed in the instructions shown on the screen. After closing the covers, the above message appears on the screen. Press **ENTER** as directed in the instructions shown on the screen. Once recovery from the error is complete, you will be able to continue working.

If the message requesting the front cover be closed does not disappear even after you close the front cover, the media may be in contact with the front cover, which will prevent the front cover from closing. In this situation, try the following methods.

- Close the front cover while holding down the end of the media.
- Pull the media to the front until it is in a position where its end is not in contact with the front cover, and then close the front cover.
- Cut the end of the media so that it is not in contact with the front cover, and then close the front cover.

If the media is still in contact with the front cover even after you try these methods, change the media.

[1 ■ 2 ■ 3 ■ 4 ■ 5 ■ 6 ■ 7 ■ 8 ■]

Ink has run out. Replace the ink pouch indicated by the flashing number with a new pouch.

[PRESS THE POWER KEY TO CLEAN]

This message appears when the machine has been unused for about one month. Switch on the sub power once a month.

☞ P. 91 "When Not in Use for a Prolonged Period"

[SHEET NOT LOADED SETUP SHEET]

Load the media. This message appears when an attempt to perform a printing test was made while no media was loaded.

[END OF THE SHEET]

The trailing edge of the media was detected during operation. Press any key on the operation panel to clear the message. Load new media.

[CHECK DRAIN BOTTLE]

This appears when a certain amount of discharged fluid collects in the drain bottle. To clear the message, press **ENTER**. If this screen appears, go to the [DRAIN BOTTLE] menu and discard the discharged fluid in the bottle.

☞ P. 63 "Disposing of Discharged Fluid"

[INSTALL DRAIN BOTTLE]

Check whether the drain bottle is installed. Install the drain bottle, then press **ENTER**.

☞ P. 63 "Disposing of Discharged Fluid"

[NOW HEATING... NOW PROCESSING..]

Wait until the dryer reaches the set temperature. Printing starts when **HEATER** lights. You can stop printing by holding down **SET UP** for one second or longer while this is displayed. Pressing **PAUSE** makes printing start immediately without waiting to reach the set temperature.

[TIME FOR MAINTENANCE]

It is time to clean the printer heads manually. After verifying the message, press **ENTER** .
☞ P. 72 "Manual Cleaning"

[TIME FOR WIPER (FELT) REPLACE]

It is time to replace the wiper or felt wiper. After verifying the message, press **ENTER** .
☞ P. 83 "Replacing the Wiper", P. 86 "Replacing the Felt Wiper"

[REMOVE MEDIA CLAMPS]

This message appears if the media clamps are attached when you try to cut off the media. Open the front cover, remove the left and right media clamps, and press **ENTER** .

An Error Message Appears

This describes the error messages that may appear on the machine's display and how to take action to remedy the problem. If the action described here does not correct the problem or if an error message not described here appears, contact your authorized Roland DG Corp. dealer.

[CLOSE COVER (FRONT COVER/COVER L/COVER R)]

Close the front, left, and right covers. For safety, the print-head carriage does not operate while a cover is open. If the message does not disappear even after you close the front cover, the media may be in contact with the front cover, which will prevent the front cover from closing. In this situation, try the following methods.

- Close the front cover while holding down the end of the media.
- Pull the media to the front until it is in a position where its end is not in contact with the front cover, and then close the front cover.
- Cut the end of the media so that it is not in contact with the front cover, and then close the front cover.

If the media is still in contact with the front cover even after you try these methods, change the media.

[CAN'T PRINT CROP CONTINUE?]

The size of the data including the crop marks is larger than the printing or cutting area of the loaded media.

To continue printing without correcting this, press **ENTER**. At this time, the portion extending beyond the printing area and the crop marks are not printed. To stop printing, stop sending data from the computer, and then raise the loading lever. Make the printing area wider, for example, by replacing the media with a larger piece of media, and then send the data again.

The size of the data being printed is too small.

Make the scanning-direction size of the data at least 65 mm (2.6 in). To continue printing without correcting this, press **ENTER**. At this time, the data is output without printing the crop marks. To stop printing, stop sending data from the computer, and then raise the loading lever. Change the size of the data, and then send the data again.

[TEMPERATURE IS TOO HIGH **°C]

The temperature of the location where the machine is installed has risen above the ambient temperature at which the machine can operate.

Operation cannot be continued. Switch off the sub power. The displayed temperature is the current ambient temperature of the installation location. Bring the temperature of the installed location to a temperature at which operation is possible (18 to 25°C (64 to 77°F)), allow the machine to come to room temperature, and then turn on the power.

[TEMPERATURE IS TOO LOW **°C]

The temperature of the location where the machine is installed has fallen below the ambient temperature at which the machine can operate.

Operation cannot be continued. Switch off the sub power. The displayed temperature is the current ambient temperature of the installation location. Bring the temperature of the installed location to a temperature at which operation is possible (18 to 25°C (64 to 77°F)), allow the machine to come to room temperature, and then turn on the power.

[HEATING TIMEOUT CONTINUE?]

The dryer did not reach the preset temperature.

This occurs because the temperature of the location where the machine is installed is too low. We recommend

raising the temperature. To continue waiting for the temperature to rise, press **ENTER**. To start printing immediately, press **PAUSE**.

[SERVICE CALL xxxx]

An unrecoverable error occurred, or part replacement that must be performed by a service technician is required.

Note the number displayed on the display screen, then switch off the sub power. After you switch off the power, inform your authorized Roland DG Corporation dealer or call center of the number that appeared on the display.

[SHEET TOO SMALL CONTINUE?]

The size of the data is larger than the printing area of the loaded media

To continue printing without correcting this, press **ENTER**. At this time, the portion extending beyond the printing area is not printed. To stop printing, stop sending data from the computer, and then raise the loading lever. Make the printing area wider, for example, by replacing the media with a larger piece of media, and then send the data again.

[SHEET SET ERROR SET AGAIN]

The loading lever was lowered while no media was loaded

Raise the loading lever, load the media in the correct position, then lower the lever again.

☞ P. 21 "Loading Media"

[SHEET TYPE] is set to "OPAQUE," but transparent media was loaded

Raise the loading lever, set the [SHEET TYPE] menu item to "CLEAR," and then reload the media.

☞ P. 107 "Using Transparent Media"

The loaded media is too small

Press any button to clear the error. Replace the media with media of a usable size.

[DATA ERROR CANCELING...]

Printing was stopped because a problem was found in the data received.

Operation cannot be continued. Check for a problem with the connector cable or the computer, and redo the operation from the step of loading the media.

[CLEANING ERROR]

Light choke cleaning was stopped due to some kind of operation.

The operation cannot be continued. Switch the sub power off by holding down the switch for one second or longer, and then switch the sub power back on again. Afterward, redo light choke cleaning from the start.

☞ P. 69 "Light Choke Cleaning"

[CANCELED FOR PUMP PROTECTION]

The printer made an emergency stop because the following state has continued for 10 minutes or longer while cleaning (normal, medium, powerful, light choke cleaning, subtank refresh, or automatic cleaning while sub power was switched off) was in progress or during the first ink filling procedure for the machine.

➤ **The printer is out of ink.**

Operation cannot be continued. Switch off the sub power. After you switch off the power, contact your authorized Roland DG Corp. dealer.

[AVOIDING DRY-UP TURN POWER OFF]

The print heads were forced to the home position to prevent them from drying out.

Operation cannot be continued. Switch the sub power off, then back on.

[SET HEAD HEIGHT TO xxx]

The height of the print heads is lower than the height specified in the software RIP.

This warning indicates that the height of the print heads is too low for the media thickness specified in the software RIP. The print-head carriage moves to a location where you can operate the height-adjustment lever. Adjust to the displayed height, then press **ENTER**.

☞ P. 106 "Adjusting Print Head Height to Match Media Thickness"

[MOTOR ERROR TURN POWER OFF]

A motor error occurred.

Operation cannot be continued. Switch off the sub power. Next, eliminate the cause of the error, and then immediately switch on the sub power. If the machine is left with the error uncorrected, the print heads may dry out and become damaged. This error may be caused by such factors as a mistake when loading the media, a media jam, an operation that pulls the media with excessive force, or an operation where the print heads were manually moved

The media has jammed.

Carefully remove the jammed media. The print heads may also be damaged. Perform head cleaning, and then perform a printing test and check the results.

The media was pulled with excessive force.

Excessive tension was applied to the media, and additional action is necessary to recover from this state. First, raise the loading lever and adjust the media to create a small amount of slack, then switch on the sub power.

The print heads were moved manually.

This message may occur if the front cover was opened and the print heads moved manually. Close the front cover, and turn the sub power off.

[PINCHROLL ERROR LOWER PINCHROLL]

This message appears when the loading lever was raised during initialization or after the media was loaded.

The error is cleared automatically after a short wait. Load the media correctly again.

[WRONG HEAD IS INSTALLED]

An unusable print head has been installed.

Operation cannot be continued. Switch off the sub power and contact your authorized Roland DG Corporation dealer.

[CANCELED FOR MOTOR PROTECTION]

The initial ink filling operation after purchase was interrupted and restarted before 10 minutes had passed.

Press any key other than the sub power switch to clear the error message. Leave the machine alone for approximately 10 minutes before resuming operation. Initial ink filling after purchase requires the pump motor to turn for a long time. To prevent failure due to the pump overheating, wait at least 10 minutes after the operation was interrupted before restarting.

[MEMORY ERROR TURN POWER OFF]

An error occurred while data was being written to or read from memory.

The operation cannot be continued. Switch the sub power off by holding down the switch for one second or longer, and then switch the sub power back on again. Afterward, redo light choke cleaning from the start.

Chapter 7

Main Specifications

Printing Area	148
Maximum Printing Area and Margins	148
Maximum Printing Area When Using Crop Marks.....	149
Media-Cutoff Location during Continuous Printing.....	149
Locations of Power Rating and Serial Number Labels	150
Specifications.....	151

Printing Area

Maximum Printing Area and Margins

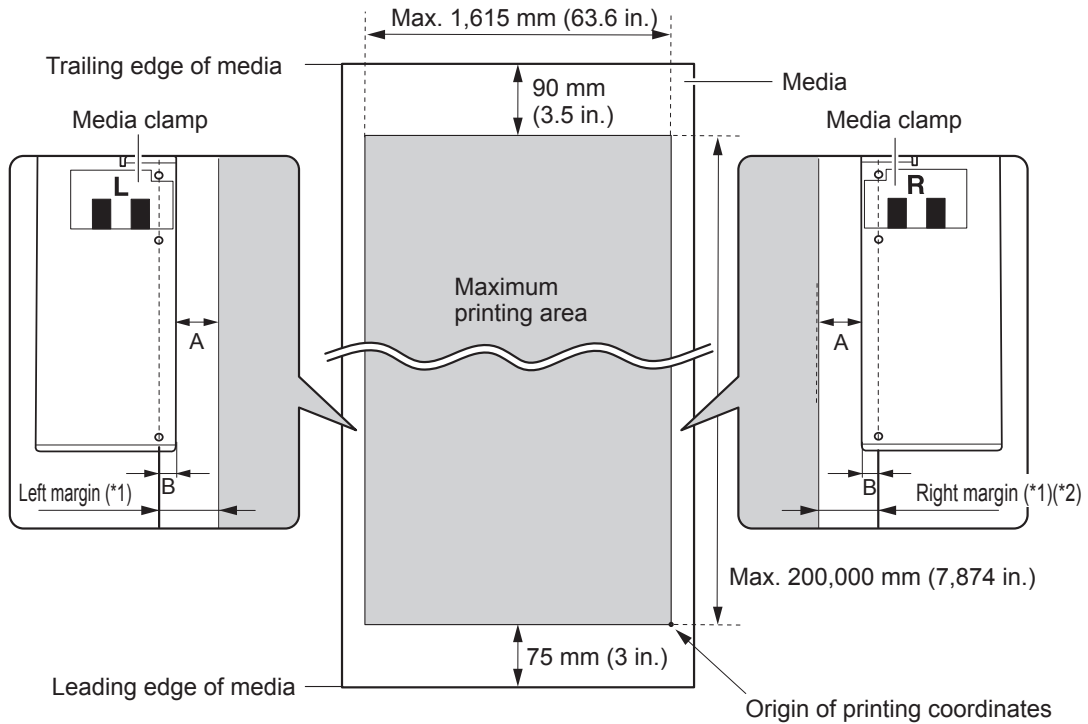

A: Setting of the [SIDE MARGIN] menu item (5 mm, 10 mm [default setting], or 25 mm (0.2 in., 0.4 in. [default setting], or 1.0 in.))

B: Width clamped by the media clamp (approx. 5 mm (0.2 in.))

*1 The width of the left and right margins is the total of A and B. In the following cases, however, the setting for A itself becomes the width of the margin.

- When media has been loaded without installing the media clamps
- When the [SHEETTYPE] menu item is set to [CLEAR] (regardless of whether the media clamps are present)

*2 You can change the width of the right margin by setting the base point (printing-start location).

☞ P. 48 "Setting the Printing-start Location"

Maximum Printing Area When Using Crop Marks

The maximum printing area when crop marks are used is reduced from the maximum printing area when crop marks are not used by an amount equal to the crop marks.

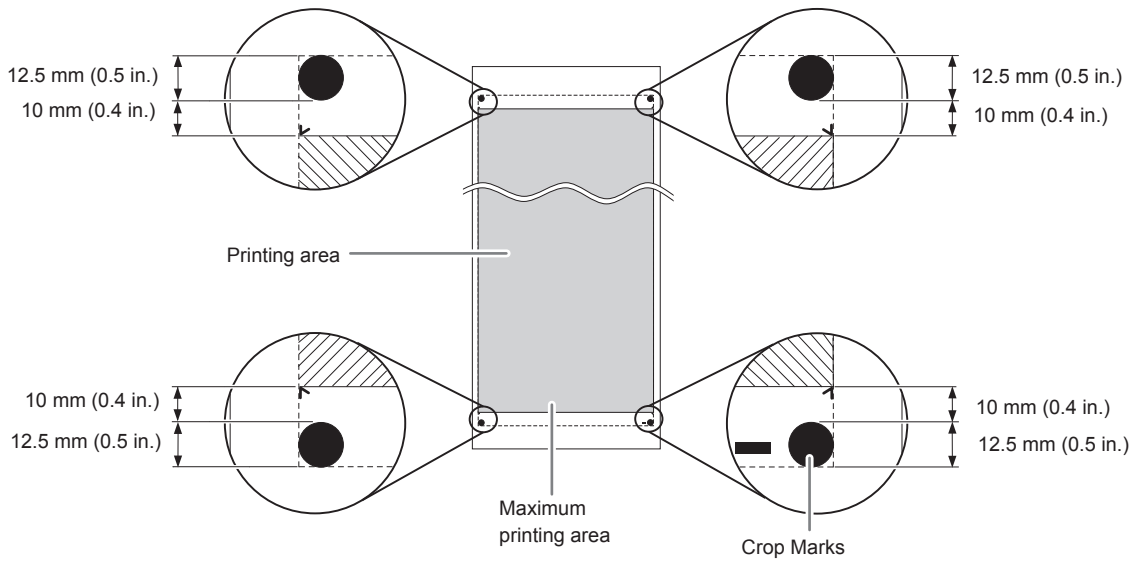

Media-Cutoff Location during Continuous Printing

When a media-cutoff command is sent from the computer, the cutoff location on the media is as shown in the figure below.

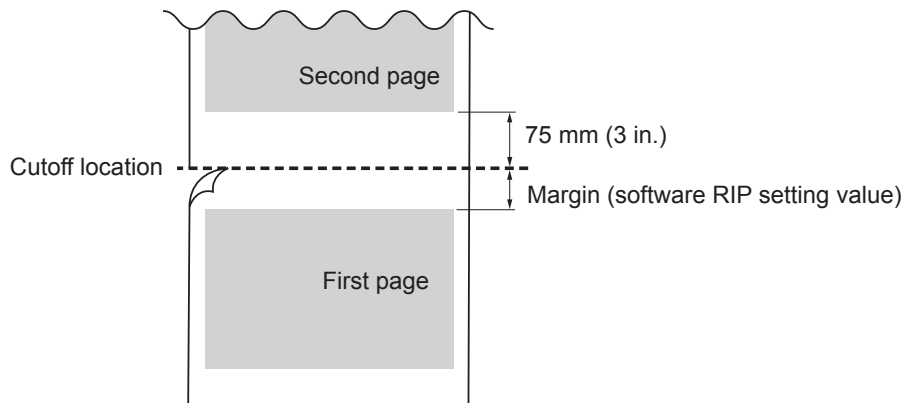

Locations of Power Rating and Serial Number Labels

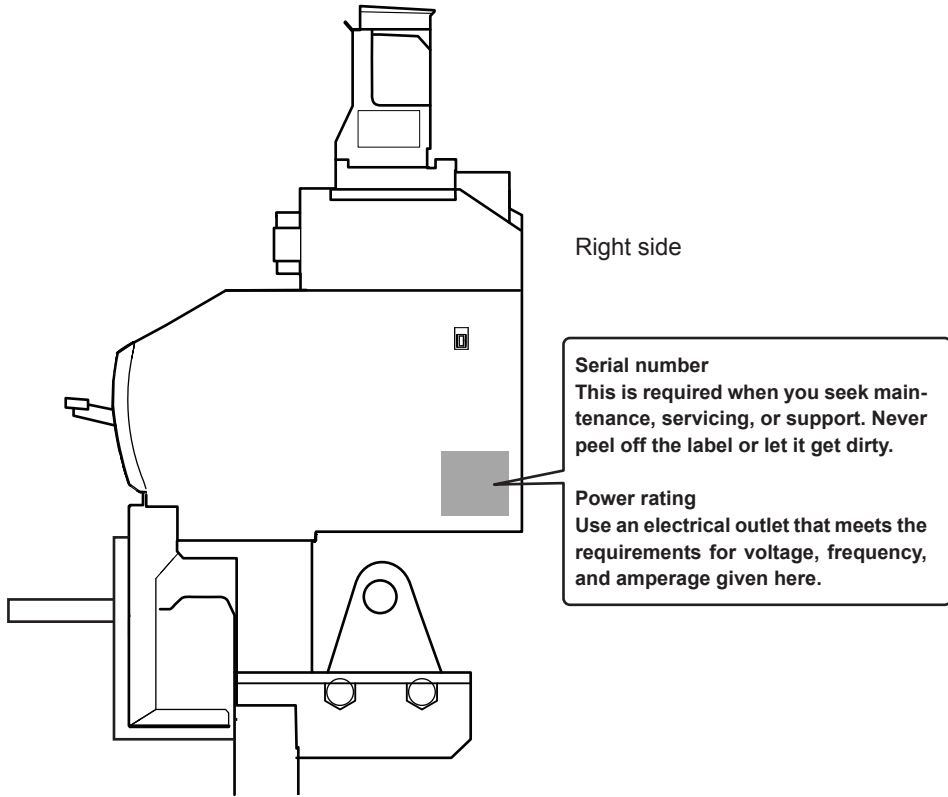

Specifications

		XT-640
Printing technology		Piezoelectric inkjet
Media	Width	259 to 1,625 mm (10.2 to 64 in.)
	Thickness	Max. 1.0 mm (39 mil)
	Roll outer diameter	Maximum 210 mm (8.3 in.)
	Roll weight	Maximum 40 kg (88 lb.)
	Core diameter (*1)	76.2 mm (3 in.) or 50.8 mm (2 in.)
Printing width (*2)		Maximum 1,615 mm (63.6 in.)
Ink	Type	Dedicated sublimation ink pouches
	Colors	Four colors (cyan, magenta, yellow, and black) Eight colors (cyan, magenta, yellow, black, light cyan, light magenta, orange, violet)
Printing resolution (dots per inch)		Maximum 1,440 dpi
Distance accuracy (*3)		Error of less than $\pm 0.3\%$ of distance traveled, or ± 0.3 mm, whichever is greater
Dryer (*4)		Dryer set temperature: 30 to 40 °C (86 to 104°F)
Connectivity		Ethernet (100BASE-TX/1000BASE-T, automatic switching)
Power-saving function		Automatic sleep feature
Power requirements		AC 100 to 120V $\pm 10\%$, 5.5A, 50/60 Hz or AC 220 to 240V $\pm 10\%$, 2.8A, 50/60 Hz
Power consumption	Power on	Approx. 750 W
	Sleep mode	Approx. 70 W
Acoustic noise level	Power on	62 dB (A) or less
	During standby	45 dB (A) or less
Dimensions (with stand)		2,835 (W) x 830 (D) x 1,650 (H) mm (111.6 [W] x 32.7 [D] x 65.0 [H] in.)
Weight (with stand)		214 kg (471.8 lb.)
Environment	Power on	Temperature: 18 to 25°C (64 to 77°F), humidity: 35 to 65% RH (non-condensing)
	Power off	Temperature: 15 to 30°C (59 to 86°F), humidity: 20 to 80% RH (non-condensing)
Included items		Dedicated stands, power cord, media clamps, media holders, replacement blade for separating knife, User's Manual, etc.

*1

The media holder of this machine is designed to be used exclusively with media that has a paper tube (core) with an inner diameter of 3 inches. To use 2-inch media, the optional media flanges are required.

*2

The length of printing is subject to the limitations of the application software.

*3

- Media type: Media specified by Roland DG Corp.
- Not guaranteed when the dryer is used.
- Temperature: 25°C (77°F), humidity: 50%
- Roll media must be loaded correctly.
- Excluding expansion/contraction of the media
- Assumes all correction and adjustment functions of the machine have been made properly.
- Print travel: 1 m

*4

- Warm-up is required after the power is turned on. This may require 5 to 20 minutes, depending on the operating environment.
- Depending on the ambient temperature and the media width, the set temperature may not be reached.
- Depending on the printing conditions, an external heater may be needed.

 Roland



1000015831

R2-160520